

ELECTRO-PNEUMATIC REGULATOR SERIES MAER300



STRÁNSKÝ A PETRŽÍK



The electro-pneumatic regulator is used for continuous electronic regulation of the output pressure based on the voltage or current input signal. The outlet pressure can therefore be dynamically adapted to the requirements of the application. The valve is also equipped with an output that can be further processed. High accuracy is achieved thanks to the integrated processor and PID control. The maximum flow at an inlet pressure of 1 MPa and an outlet pressure of 0,6 MPa is up to 4000 Nl/min.

i A model controlled by RS-232 / RS-485 with Modbus protocol is also available. For more information, contact the technical department.

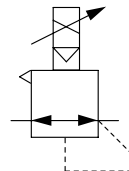

Type		MAER300		
Pressure range (see order code)		1K	5K	9K
Port size		in/out: G1/4", G3/8", G1/2", relief: G1/2", control exhaust: M5		
Medium		modified compressed air		
Test pressure [MPa]		0,3	1,5	1,5
Temperature range [°C]		-5 to +50		
Min. supply pressure [MPa]		set pressure + 0,1		
Max. supply pressure [MPa]		0,2	0,7	1,0
Setting pressure range [MPa]		0,005 to 0,1	0,005 to 0,5	0,009 to 0,9
Supply voltage [V]		24V DC ±10%		
Power consumption [A]		0,08 or less		
Input signal	current type [mA]	DC, 4 to 20, impedance ≤ 400 Ω		
	voltage type [V]	DC, 0 to 5, or 0 to 10, impedance approx. ≤ 50 kΩ		
	preset input	4 points (one point should be set to zero due to safety reasons, combinations of 2 input signals), impedance approx. ≤ 1000 kΩ		
Output signal	analog	DC output current 4 to 20 mA (load impedance 750Ω or less), DC output voltage 1 to 5 V (load impedance 1kΩ or above)		
	switch	PNP or NPN output, max. voltage 24V DC, max. current 160 mA		
Linearity		within ±1% F.S.		
Hysteresis		within 0,5% F.S.		
Repeatability		within ±0,5% F.S.		
Sensitivity		within 0,2% F.S.		
Temperature characteristics		within ±0,2% F.S./°C		
Output pressure display		precision: ±2% F.S., ±1 digit, min. unit: 0,001 (MPa), 0,01 (bar, kg/cm ²), 0,1 (psi), 1 (kPa)		
Enclosure		equivalent to IP65		
Weight [kg]		valve: 0,69, bracket: 0,086 (L type), 0,08 (flat type), connector with cable: 0,055 (1m), 0,13 (3m)		

Order codes

PMAER300 10A 9K 2 3 3

Port size	
8A	G1/4"
10A	G3/8"
15A	G1/2"

Pressure range	
1K	0,005 to 0,1 MPa
5K	0,005 to 0,5 MPa
9K	0,009 to 0,9 MPa

Input signal	
1	current 4-20 mA
2	voltage 0-10 V
3	voltage 0-5 V
4	4 preset points

Output signal	
1	analog, voltage 1-5 V
2	switch, NPN
3	switch, PNP
4	analog, current 4-20 mA
0	for input signal 4

Display unit	
3	bar

i The pressure unit can be changed in the settings. Available options are: MPa, kg/cm², bar, psi, kPa.

Order codes - accessories

Description	Order code	Description	Order code	Description	Order code
L type bracket	PMAER200-B1	Straight connector, cable 1 m	PMAER200-S1	L type connector, cable 1 m	PMAER200-L1
Flat type bracket	PMAER200-B2	Straight connector, cable 3 m	PMAER200-S3	L type connector, cable 3 m	PMAER200-L3

Capacity

Flow rate

Pressure range 1K

Supply pressure 0,2 MPa

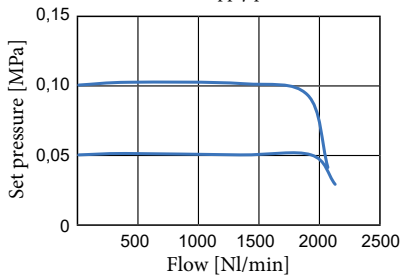

Pressure range 5K

Supply pressure 0,7 MPa

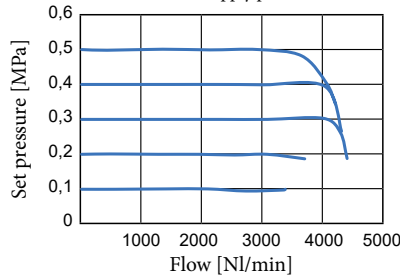

Pressure range 9K

Supply pressure 1,0 MPa

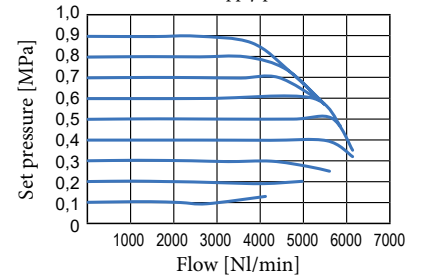

Relief flow rate

Pressure range 1K

Back pressure 0,2 MPa

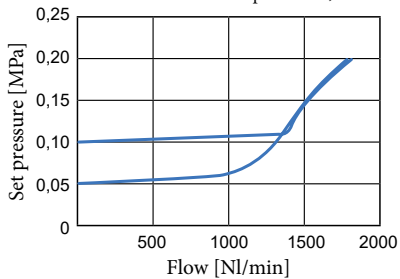

Pressure range 5K

Back pressure 0,7 MPa

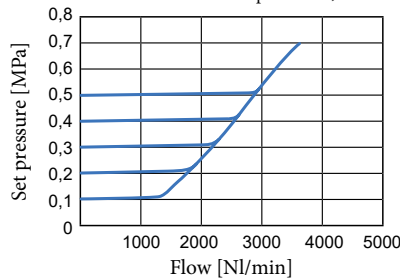

Pressure range 9K

Back pressure 1,0 MPa

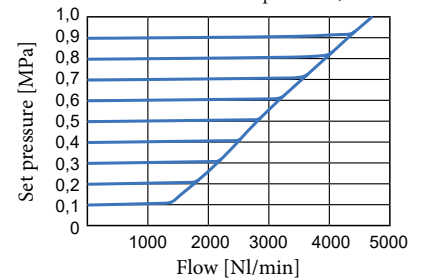

Dimensions

MAER300 with L type bracket

MAER300 with flat type bracket

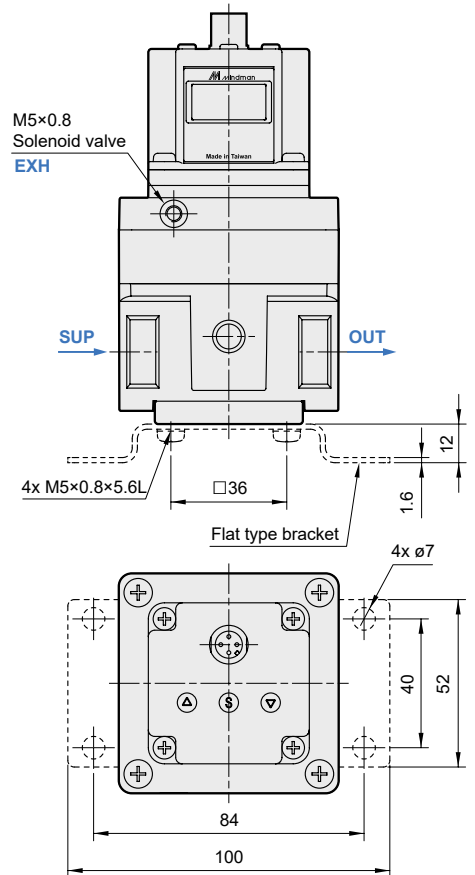
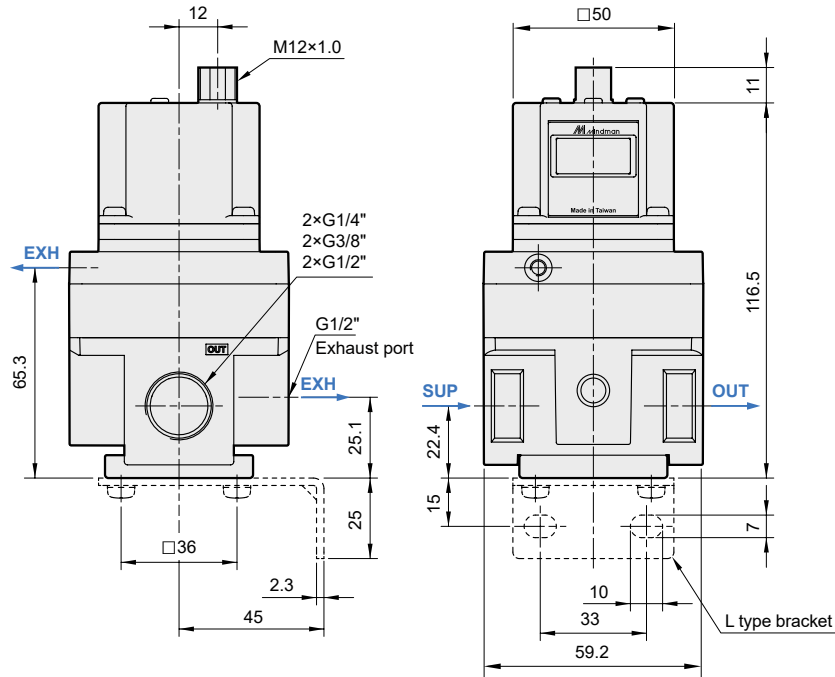

Connectors

