

A new type of solenoid pilot actuated valve, which offers not only a large flow rate, high durability but also better availability. Valves can be used as standalone or they can be mounted on manifolds. They can replace L1 and L2 series valves because they have the same connection dimensions, unlike the L1/L2 series, the coil can be rotated in the desired direction. Connector and coil are included in delivery.

Valves series K contains spool and sleeve assembly, which guarantee long lifetime of valve.



Series	K1		K2		K3
Port	G1/8"	G1/4"	G1/4"	G3/8"	G1/2"
Connection of external pressure supply port	M5	M5	M5	M5	G1/8"
Flow capacity [NI/min]	1000	1000	1700	1700	3500
Working pressure [MPa]	0.15 to 1.0 (vacuum to 2.1 when external pilot supply is used)				
Pilot pressure range [MPa]	0.15 to 1.0				
Power input [W/VA] (standard coils)	3W for DC voltage, 7.5 VA inrush and 5 VA hold for AC voltage				
Response time for DC voltage [ms]	10 energize, 35 de-energize				
Response time for AC voltage [ms]	7 energize, 35 de-energize				
Temperature range [°C]	medium temperature max. 50, ambient temperature -20 to +50				
Enclosure (standard coils)	IP65 with sealed and fastened connector				

**Order codes**

25 528090 06 30 3 000

Function		
52 80 90		5/2 monostable (with 1 coil)
52 80 80		5/2 bistable (with 2 coils)
53 80 80		5/3 with exhaust centre position
73 80 80		5/3 with pressure centre position (for series K1 and K2 only)

Port	
04	thread G1/8" (for series K1)
06	thread G1/4" (for series K1 or K2)
08	thread G3/8" (for series K2)
10	thread G1/2" (for series K3)

Voltage	
30	24 V DC ± 10%
40	24 V AC ± 10% 50-60 Hz
50	110 V AC ± 10% 50-60 Hz
60	230 V AC ± 10% 50-60 Hz
31	24 V DC ± 10% ATEX II 2G(D)*

Series	
2	K1 (thread G1/8" or G1/4")
3	K2 (thread G1/4" or G3/8")
4	K3 (thread G1/2")

\*)See detailed specification of ATEX coil on the next page

**i** Supply contains connector(s).

**i** For information about manifold assembly see page 5-5.

**i** A special 5/3 valve design is available for the K2 series  
  
 The order code is:  
 25 63 80 80 06 xx 3001, where xx is the coil voltage from the standard order code. The dimensions are identical to the function 538080.

**i** For the K series, a version for ambient temperatures from -40 to +80°C is available. The connector connection to the coil complies with DIN 72585, used in the automotive industry. More detailed information about this version can be found on our website [www.sappv.cz/r/e04e](http://www.sappv.cz/r/e04e)



Dimensions of valve series K

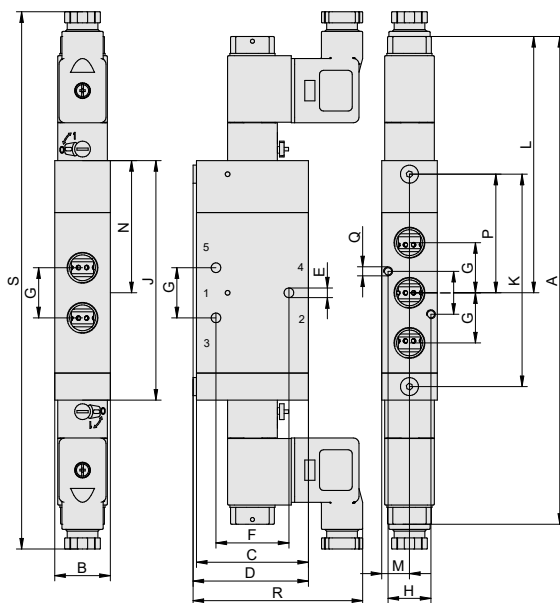
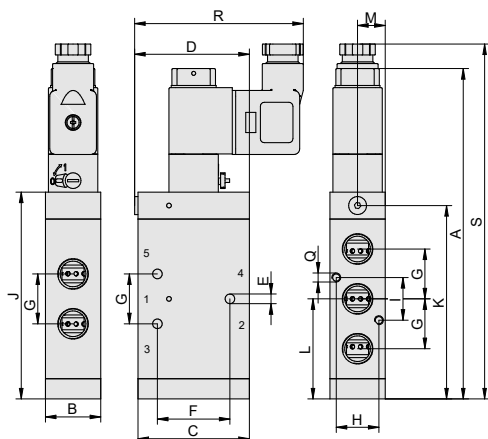

Series	Function	A	B	C	D	E	F	G	H	I	J	K	L	M	N	P	Q	R	S	Weight [kg]
K1	52 80 90	136	22	42	43.5	3.3	24.4	18	15.8	18	81	75	39	11	—	—	M3, deep 7	71	147	0.312
K1	52 80 80	204	22	42	43.5	3.3	24.4	18	15.8	18	94	82	107	11	52	46	M3, deep 7	71	226	0.420
K1	53 80 80	214	22	42	43.5	3.3	24.4	18	15.8	18	104	92	107	11	52	46	M3, deep 7	71	236	0.460
K1	73 80 80	214	22	42	43.5	3.3	24.4	18	15.8	18	104	92	107	11	52	46	M3, deep 7	71	236	0.460
K2	52 80 90	147	24.6	49.6	51.1	4.3	32.3	22.2	19	19	92.1	86.1	44.6	12.3	—	—	M4, deep 7	75	158	0.345
K2	52 80 80	216	24.6	49.6	51.1	4.3	32.3	22.2	19	19	106.1	94.1	113	12.3	58.6	52.6	M4, deep 7	75	238	0.430
K2	53 80 80	227	24.6	49.6	51.1	4.3	32.3	22.2	19	19	117.1	105.1	113	12.3	58.6	52.6	M4, deep 7	75	249	0.479
K2	73 80 80	227	24.6	49.6	51.1	4.3	32.3	22.2	19	19	117.1	105.1	113	12.3	58.6	52.6	M4, deep 7	75	249	0.479
K3	52 80 90	223	44	66	68.5	5.3	44	32	35	16	168	159.5	80	22	—	—	Ø5.3	85	234	1.380
K3	52 80 80	268	44	66	68.5	5.3	44	32	35	16	176	159	143	22	88	79.5	Ø5.3	85	308	1.441
K3	53 80 80	297	44	66	68.5	5.3	44	32	35	16	186	169	148	22	93	84.5	Ø5.3	85	318	1.576

Notice: use fittings only to max. 19 mm wrench size with series K2.

Spare coils for valve series K

Standard coils type 22

Order code	Voltage	Coil type	Weight [kg]
2500 8181 0030 0013	24V DC	DIN 43650B	0.06
2500 8181 0040 0010	24V 50-60 Hz	DIN 43650B	0.06
2500 8181 0060 0009	230V 50-60 Hz	DIN 43650B	0.06
PMVSC220-COA110	110V 50-60 Hz	DIN 43650B	0.06



Coil type 22 with ATEX Ex certification

Order code	Voltage	Cable length [m]	Weight [kg]
2500 8181 0030 0014	24V DC	5	0.46

Ex II 2G Ex mb IIC T5 Gb U=24V DC ±10%  
 Ex II 2D Ex tb IIIC T95°C Db IP66 I=125 mA  
 P=3W  
 Ta=-20°C to +50°C

Notice: The connector is fastened with a M3 screw with a maximum torque of 0.4 to 0.6 Nm

Conversion of internal to external air pilot supply

External air pilot supply is used, when air supply pressure is lower than 0.1 MPa (1 bar) as well as for vacuum and or if another medium than compressed air is used. It is necessary to change standard setting (when air pilot supply is drawn from valve supply port 1) in that cases.

When converting from internal to external pilot supply, please proceed as follows:

- 1) Dismount connector
- 2) Unscrew for M3 screws, remove valve lid with pilot valve, pay attention to the O-ring between the cover and the valve body
- 3) Remove the pin from the valve body and insert it into the hole with the O-ring in the lid, check if the O-rings fits correctly in the lid and put the lid back (tightening torque 1.5 Nm), insert and fasten the connector
- 4) Unscrew plug on side of valve and connect modified compressed air with pressure 0.1 to 1.0 MPa

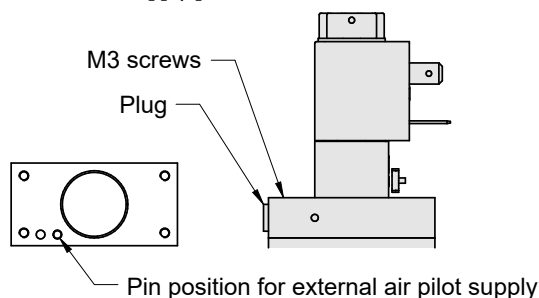



**Series K valves manifold assembly**

Manifolds for K series valves are supplied separately and it is necessary to use one pair of end plates, which are also used as manifolds for 2 valves, and requested number of middle plates (1 plate for 1 valve) to create the complete manifold assembly. It is possible to add other positions to the assembly at any time, just remove the end plate and add additional middle plates. If it is necessary to create a reserve during assembly, it is recommended to use a blank station plate, which can be easily replaced by valve. Max. number of valves in one manifold is 10. Any valve series K may be used for manifold assembly (it doesn't matter if valve is single or double solenoid actuated or air actuated). But it is necessary to use adaptor, which must be mounted between valve and manifold. Valves mounted on manifold could be unmounted separately by unscrew of 2 bolts, which are accessible from top side (side with ports 2 and 4 of valves).

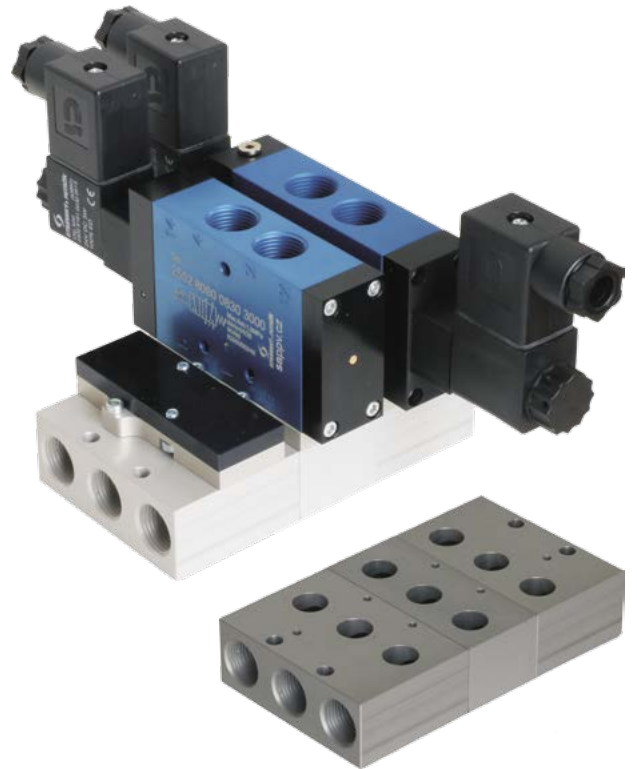

Series	Order code	Weight [kg]	Application
K1	2500 8181 0600 0003	0.26	End plates (1 pair) for 2 valves
K1	2500 8181 0600 0002	0.08	Middle plate (extension for 1 valve)
K1	2500 8181 0600 0001	0.02	Adaptor plate (1 plate per station)
K1	2500 8181 0600 0004	0.05	Blank station plate
K2	2500 8181 0800 0001	0.29	End plates (1 pair) for 2 valves
K2	2500 8181 0800 0002	0.11	Middle plate (extension for 1 valve)
K2	2500 8181 0800 0003	0.04	Adaptor plate (1 plate per station)
K2	2500 8181 0800 0005	0.07	Blank station plate



Adaptor plate for mounting the valve on the manifold (1 plate per station)

**Assembly procedure:**

- 1) On the middle plate, check that the sealing rings in the recesses are seated correctly. Place the middle plate on the end plate pins and secure with two countersunk screws.
- 2) Repeat the procedure with the other middle plates.
- 3) On the other end plate, check that the sealing rings are seated correctly in the recesses. Place the end plate on the pins of the middle plate and secure with two countersunk screws.
- 4) Mount the adapter on the inlet and exhaust side (ports 1,3,5) on the valve using two M4x10 screws. Make sure that the sealing rings are fitted correctly in the recesses.
- 5) Mount the valve with the adapter using two M3x12 screws in the required position on the manifold. Make sure that the sealing rings are fitted correctly in the recesses.
- 6) Fasten the manifold with valves with all four holes  $\varnothing E$ .

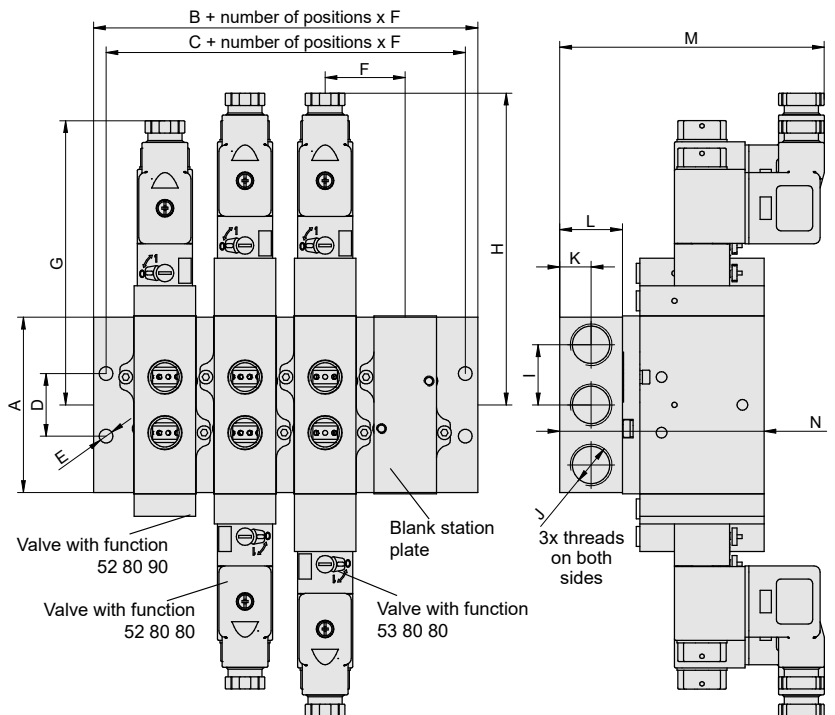

Series	A	B	C	D	E	F	G	H	I	J	K	L	M	N
K1	59	26.5	16.5	21	5.5	30.5	108	118	21	G1/4"	12.5	25	100	72.5
K2	69	25.5	15.5	25	5.5	32	113.5	124.5	24	G3/8"	12.5	25	106	82

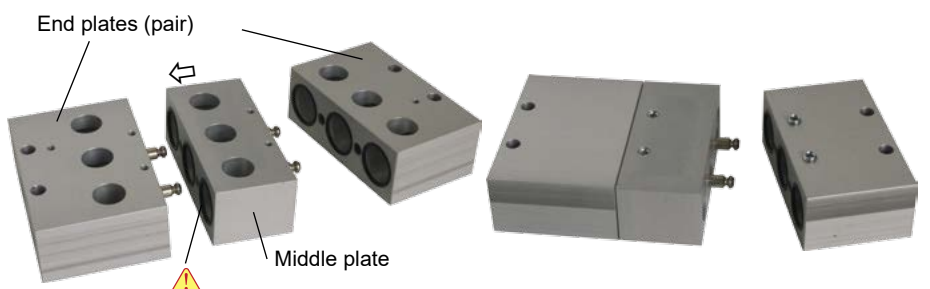

**i** For more information about assembly see [sappv.cz/r/e05e](http://sappv.cz/r/e05e)