

PROXIMITY SWITCHES SERIES RZT7 AND MZT8



These proximity switches are produced as reed switches or electronic switches. Advantage of these switches is that they can be used with all types of Stránský a Petržík's cylinders. It means, that there can be used not only several diameters but also more types of cylinders (VDMA, compact, DIN ISO, etc.) in pneumatic circuit and for all cylinders only one type of switch can be used (it is necessary to select proper bracket for various types of cylinder - see table below). It brings cost savings at designing electrical circuits, at connection as well as at circuit maintaining.

Switch can be used with cylinders with T-slot made by other producers.

Technical data of series RZT7

Description	Value
Supply voltage U_b [V]	5 to 30 DC / AC
Max. switching power [W]	≤ 6
Continuous current I_a [mA]	≤ 500 (DC), ≤ 300 (AC)
Overrun distance, typ. [mm]	10
Enclosure rating to EN 60 529	IP 67
Temperature range T_a [°C]	-20 to +70
Housing material	plastic
Cable	PVC, 3 x 0.12 mm ²
Function indicator	LED
Integrated short circuit (max. 8A) and reverse polarity protection	

Technical data of series MZT8

Description	Value for switching output	
	PNP and NPN	NAMUR EN 60947-5
Supply voltage U_b [V]	10 to 30 DC	8,2 to 20 DC ¹⁾
Voltage drop U_d [V]	≤ 2.2	
Power consumption [mA]	≤ 10	
Continuous current I_a [mA]	≤ 200	≤ 60
Overrun distance, typ. [mm]	3	
Enclosure rating to EN 60 529	IP 68	IP 67
Temperature range T_a [°C]	-30 to +80	-25 to +80
Housing material	plastic PA12	
Cable	PUR, 3 x 0.14 mm ²	PVC, 2 x 0.14 mm ²
Function indicator	LED	
Integrated short circuit, reverse polarity and power-up pulse protection		

Order codes

Type	Switching output	Function	Max. switching frequency [Hz]	Sensitivity [mT]	Order codes for switch with connection		
					cable 2m	cable 5m	cable 0.3 m with connector M8x1
RZT7	reed	normally open (NO)	400	3	2201 2810 0510 2000	2201 2810 0510 5000	2201 2810 0515 0000
MZT8	PNP		1000	2.6	2202 2511 0210 2000	2202 2511 0210 5000	2202 2511 0215 0000
MZT8	NPN		1000	2.6	—	—	2202 2611 0215 0000
MZT8	NAMUR ATEX ¹⁾		1000	2.8	2202 2714 5610 2000	2202 2714 5610 5000	—

1) According NAMUR EN 60947-5-6. Using of isolated switch amplifier with certificates of conformity for explosion areas is recommended ($U \leq 20$ V; $I \leq 60$ mA; $P \leq 100$ mW), device labeling: II 1D Ex ia IIC T135 °C Da, II 1G Ex ia IIC T4 Ga



Please read carefully technical information on page 3-9.

How to fix switch on cylinder and which series for which cylinder type

Pneumatic cylinder type	Switch can be used					
	directly	with bracket	with bracket for dovetail groove	With bracket for tube		
				up to Ø25	up to Ø63	up to Ø125
VDMA 24562, CNOMO		✓				
VDMA 24562 with integrated grooves, Compact, ISO 15552 (order code 10201...), short stroke Ø160 and 250 mm	✓					
DIN ISO 6432, PDSW, anti-corrosive - hygienic clean				✓		
Short stroke, Ø20 to 100 mm			✓			
Rotary actuator, Ø 20 to 40 mm				✓	✓	
Rotary actuator, Ø50 and more mm		✓				
With guide unit U or H*		✓		✓	✓	✓

* We recommend to use bracket for tube with cylinder with guide unit, to provide sensing in section, where the guide unit is mounted. The guide body inhibits using of bracket for tie rod / profile. On the other side, or in the area out of guide body, bracket for tie rod / profile can be used.

Dimensions of series RZT7

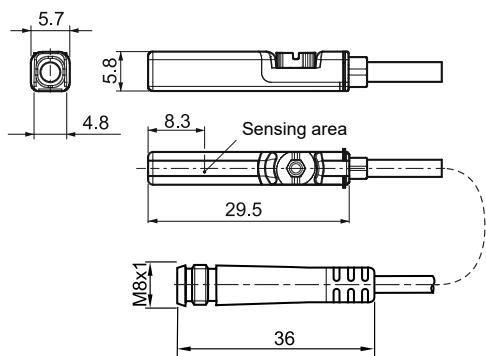

Dimensions of series MZT8

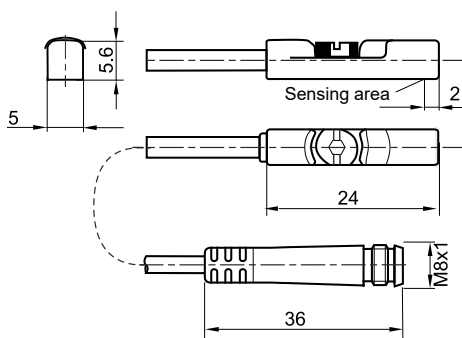

Connection

reed, PNP, NPN

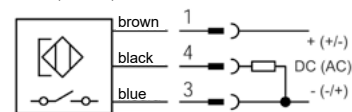

NAMUR

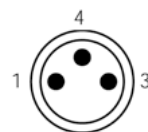
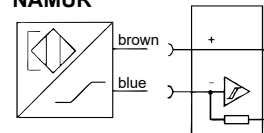

Wire colour	Pin	Assignment
brown	1	+V DC
black	4	NO
blue	3	-V DC

Brackets for switches series RZT7, MZT8

Bracket for tie rod / profile



Order code	Ø tie rod / profile
2290 2010 0000 0000	5 to 18

Bracket for dovetail groove



Order code	Profile
2290 2011 0000 0000	dovetail gr.

Bracket for round tube



Order code	For cylinder
2290 2012 0000 0000	up to Ø25
2290 2013 0000 0000	up to Ø63
2290 2014 0000 0000	up to Ø125

suitable for cylinders with tie rods or profile tubes cylinders to ISO 6431, VDMA 24562 (except guide unit U or H) and CNOMO, tie rod diameter / profile width: 5 to 18 mm

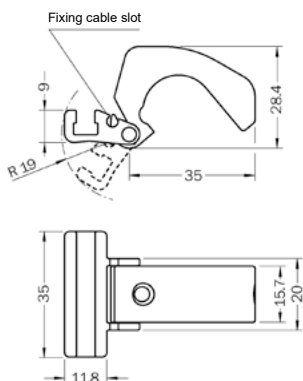

suitable for short stroke cylinders with dovetail groove

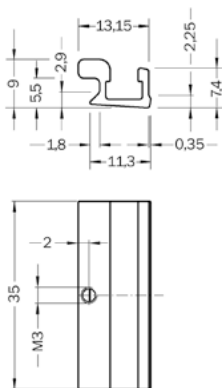

up to Ø25: suitable for cylinders with round tube (ISO 6432 and rotary actuators dia. 20-32) and cylinders to VDMA 24562 with guide unit U or H diameter 32

up to Ø63: suitable for cylinders with round tube (rotary actuator dia. 40) and cylinder to VDMA 24562 with guide unit U or H dia. 40 to 63

up to Ø125: suitable for cylinders with round tube and cylinders to VDMA 24562 with guide unit U or H dia. 80 to 125

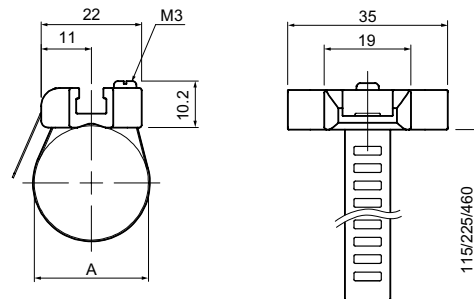

Cables with M8x1 connector

Description	Order codes - straight connector	Order codes - elbow connector
Connector only for cable max. 3x0.25 mm ² , max. dia. 5.5 mm	2291 0001 0000 0000	2291 0002 0000 0000
PVC cable with connector 3x0.22 mm ² , length 2m	2291 0010 0000 0000	2291 0015 0000 0000
PVC cable with connector 3x0.22 mm ² , length 5m	2291 0011 0000 0000	2291 0016 0000 0000
PVC cable with connector 3x0.22 mm ² , length 10m	2291 0012 0000 0000	2291 0017 0000 0000



Warning

Do not exceed specification, permanent damage to the sensor may occur.

Rules for using of proximity switches

- For reed switch type sensors, polarity must also be observed for the proper functioning of LED. Connect the brown wire in series with load positive (+) and the blue wire to negative (-) of power source. If the polarity is reversed, reed switch remains functional but LED will remain in "OFF" state.

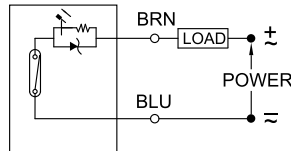

- For solid-state type sensors, polarity must also be observed. Connect brown (red for SP-472 switch) wire to the positive (+) and the blue to the negative (-) of DC power source. The black (white for SP-472 switch) wire must connect to the load only. If the black (white for SP-472 switch) wire is accidentally connected to the power source, permanent damage to the sensor may occur.

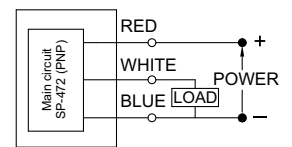
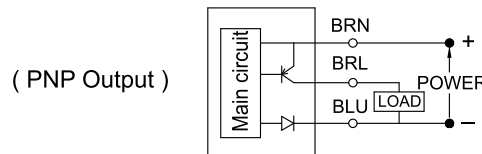
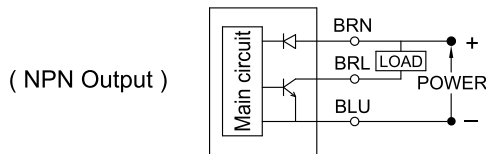

- An external protection circuit may be required if the reed switch is used with inductive load. For DC voltage, the diode must be connected, for AC voltage, the RC circuit must be connected as shown below.

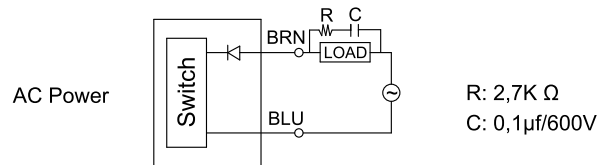
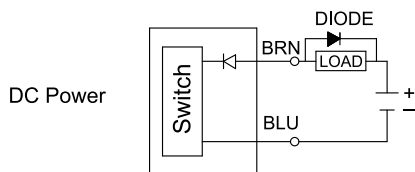

- Keep sensors away from stray magnetic field to prevent malfunctions.
- When using reed switch with capacitive load or if the lead wire length exceed 10 meters, an inductor must be installed in series.

