



Pressure boosters (pressure amplifiers) are used to increase the pressure delivered by a compressor at the expense of proportional flow loss. They do not replace the compressor, but provide a higher pressure for a limited time. They are usually used to increase the force of pneumatic cylinders while maintaining smaller overall dimensions and weight, for high-pressure blowing, component testing, pressure testing, etc.

Working (supply) pressure	0,3 to 1,0 MPa
Temperature range	-20°C to +50°C
Working medium	modified compressed air
Installation	horizontal

Piston diameter [mm]	63	100
Connection	inlet G3/8", others G1/8" (G3/8")	inlet G1/2", others G1/8" (G1/2")
Pressure increase rate	2 or 3	2 or 3
Supply pressure [MPa]	0,3 to 1,0	0,3 to 1,0
Operating (output) pressure [MPa]	0,4 to 1,8 (2,8)	0,4 to 1,8 (2,8)
Flow capacity [NI] at supply pressure 0,5 MPa and output pressure 0,8 MPa	200	250
Weight for output pressure 2,0 MPa[kg] / foot mounting	2,8 / 0,443	9,7 / 0,443

### Order codes

A BS001 063 12

Piston diameter		Output pressure	
063	63 mm	12	2,0 MPa
100	100 mm	13	3,0 MPa

### Operation notes

#### Connection to the compressed air network and functions

In case of direct connection of the booster to the system, a 3/2 valve (6) should be used to open and close the circuit at the output of the multiplier. An air filter should also be included at the output, as the booster contains moving

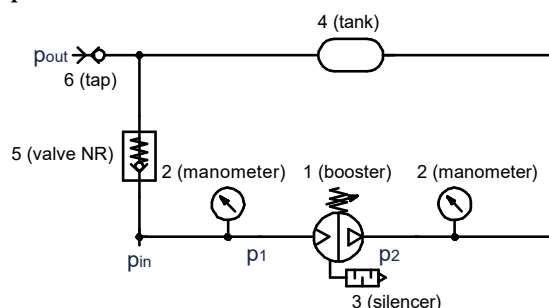

parts. A filter should be included at the input to separate water and mist from the air, the air must not be lubricated. The booster provides high-pressure air in a "pulsating" manner, therefore it is recommended to use an air tank (4) at the output of the booster to avoid pulsation during use. To speed up the initiation/filling of the system, it is recommended to connect a one-way check valve, as shown in figure (5). The selection of a pressure booster does not only include the compression ratio, but above all a sufficient volume of the air tank to ensure the correct supply of the consumers. First, it is necessary to calculate the volume of air taken by the consumers (cylinders, blowing nozzles, etc.), and then determine the corresponding volume of the air tank. Silencers must be installed on the operating exhausts (not included). The booster is activated automatically as soon as the inlet pressure (p1) is applied and operates until the outlet pressure (p2) reaches twice the inlet pressure (at a compression ratio of 1:2) or three times (at a ratio of 1:3). The booster is not designed for free exhaust operation, but always requires a connected application. The outlet pressure can be regulated using a pressure regulator if necessary. If no air is being extracted at the outlet, the integrated check valves allow the increased pressure to be maintained even if the inlet pressure is removed.

### Dimensions

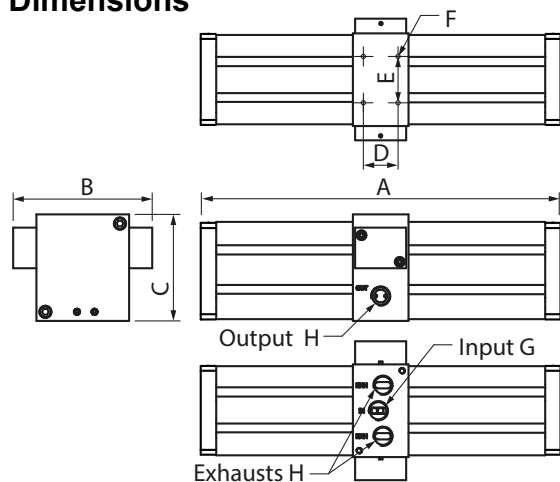

∅	Output pressure	A	B	C	D	E	F	G	H
63	2,0 MPa	284	120	92	30	40	M4	G3/8"	G1/8"
63	3,0 MPa	470	149	109	50	70	M8	G1/2"	G1/8"
100	2,0 MPa	259	120	92	30	40	M4	G3/8"	G3/8"
100	3,0 MPa	451	149	109	50	70	M8	G1/2"	G1/2"

### Accessories

Description	Order code
Foot mounting, for ∅63 (1 piece)	ABSCP 063
Foot mounting, for ∅100 (1 piece)	ABSCP 100
Pressure regulator G1/2" 0,05-2,5 MPa incl. gauge	2913 0000 1000 0012
Pressure regulator G3/8" 0,2-3,5 MPa incl. gauge	2913 0000 0800 0003

**Technical data**

**Piston diameter 63 mm - output pressure 2,0 MPa**

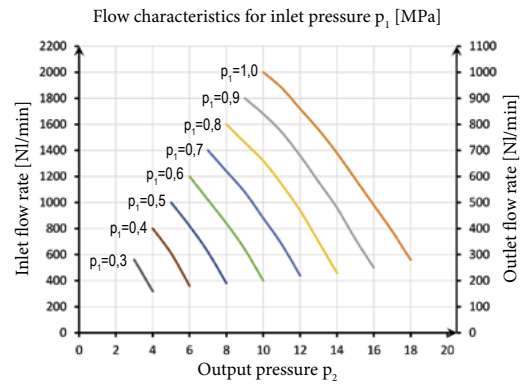
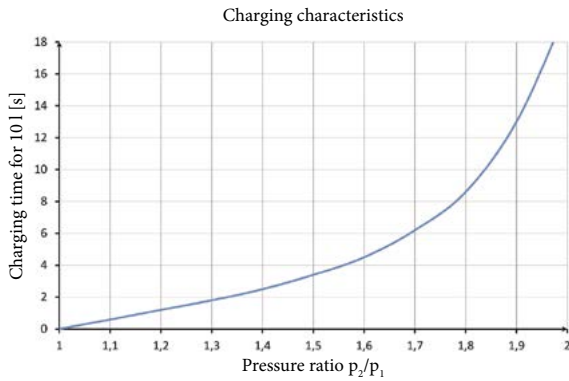

**Piston diameter 63 mm - output pressure 3,0 MPa**

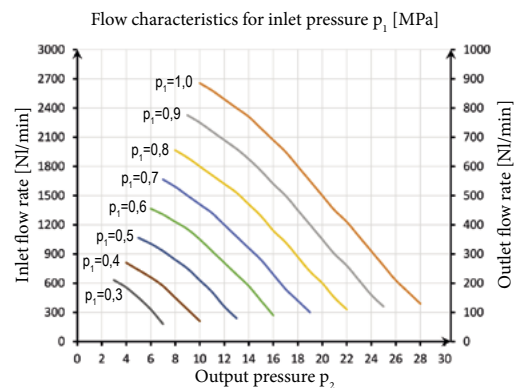
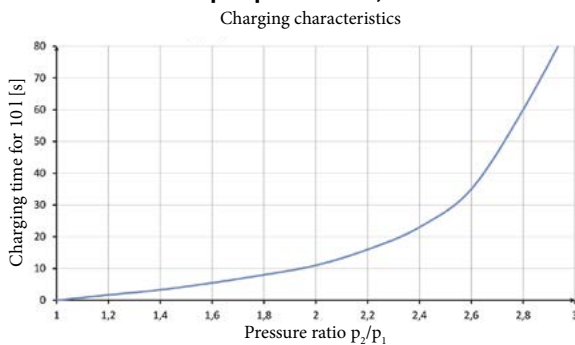

**Piston diameter 100 mm - output pressure 2,0 MPa**

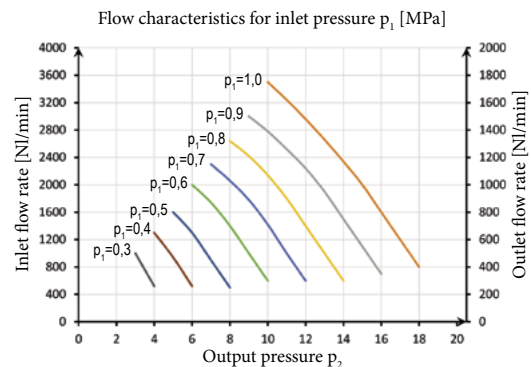
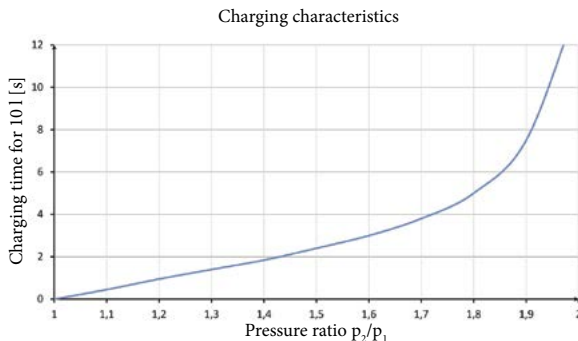

**Piston diameter 100 mm - output pressure 3,0 MPa**

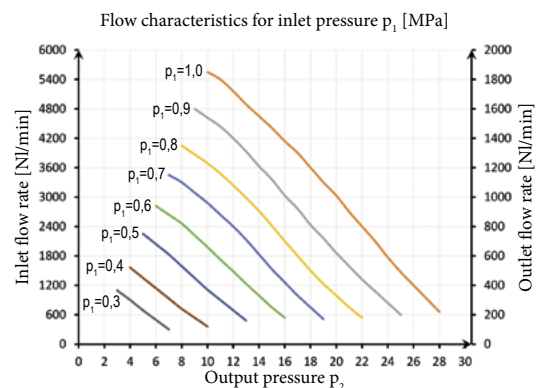
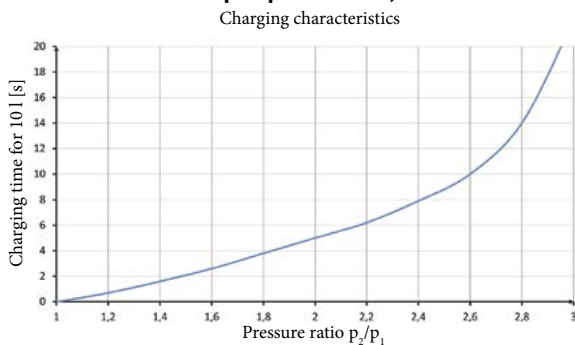

**Calculation of the filling time of the tank**

Example of calculating the filling time of a tank with a volume of 50 liters when increasing the pressure from the starting pressure of 0,7 MPa to the final pressure of 0,9 MPa using the pressure amplifier PBS00106312 with an input pressure of 5 bar. Values for the calculation: input pressure:  $P_1 = 0,5$  MPa, initial pressure in the tank:  $STP = 0,7$  MPa, final pressure in the tank:  $FTP = 0,9$  MPa, tank volume:  $V = 50$  l. We calculate the ratio  $STP/P_1$  and  $FTP/P_1$ , i.e.  $0,7/0,5=1,4$  and  $0,9/0,5=1,8$ . From the graph, we determine the time values corresponding to the specified pressure ratios, i.e. for  $P_2/P_1=1,4$  it is a value of approximately 2,5 s, for a ratio of 1.8 it is a value of 8,5 s. We subtract the values, i.e.  $8,5-2,5=6$  s. The pressurization time of 10 l to a pressure of 0,9 MPa under the specified conditions is 6 s. Pressurization of 50 l will therefore be a multiple of  $6 \times 5=30$  s.