



Pneumatic pressure boosters series MVBA are used for increasing of air pressure. These booster regulators are able to twice increase inlet pressure, but due to safety, the maximal output pressure is up to 1,6 MPa. Boosters can be used in applications, where there is no sufficient pressure in regular distribution. The advantage is, that no additional power is required, so also heat generation is reduced. They are fully autonomous and they start to „produce“ high pressure air, when compressed air is brought to inlet port. **For more information, please visit our web page on www.sappv.cz/r/w14e**

Working (supply) pressure	0,1 to 1,0 MPa
Temperature range	+2°C to +50°C
Working medium	modified compressed air
Installation	horizontal

Type	MVBA2100	MVBA4100	MVBA4300
Connection	G3/8"	G1/2"	
Pressure increase rate	max. 2	max. 2	
Supply pressure [MPa]	0,1 to 1,0	0,1 to 1,0	
Operating (output) pressure [MPa]	0,2 to 1,0	0,2 to 1,0	0,2 to 1,6
Flow capacity [NI] at supply pressure 0,5 MPa and output pressure 0,8 MPa	1000	1600	
Weight [kg]	3,9	9,4	9,5

Order codes

P MVBA 2100

Booster		Type	
MVBA	pneumatic	2100	G3/8", max. 1 MPa
		4100	G1/2", max. 1 MPa
		4300	G1/2", max. 1,6 MPa

Operation notes

- If the outlet capacity is undersized, pulsation may occur.
- Make sure to install a mist separator at the inlet side of the booster regulator, supply air must be dry - non lubricated
- The booster regulator has a sliding part inside, and it generates dust. Also, install a cleaning device such as an air filter or a mist separator on the outlet side as necessary.
- Depending on the necessity, install a silencer on the exhaust port of the booster regulator to reduce the exhaustion sound.
- Provide a dedicated pipe to release the exhaust air from each booster regulator. If exhaust air is converged into a pipe, the back pressure that is created could cause improper operation.

Dimensions

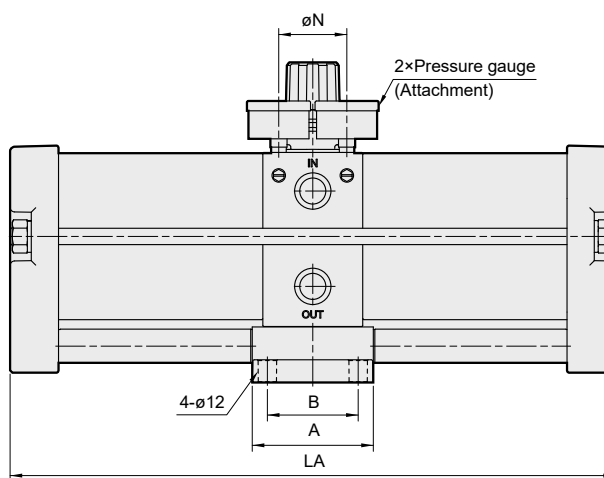
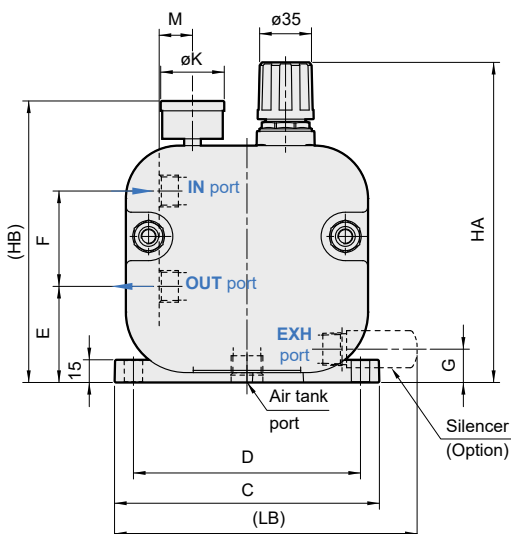

Typ	A	B	C	D	E	F	G	HA	HB	AA	AB	K	M	N
2100	73	53	118	98	46	43	18	172,5	140	295	168	24	8	30
4100	80	60	175	150	63,5	63	22	211,5	186	400	200	42	22	45
4300	80	60	175	150	63,5	63	22	221,8	186	400	200	42	22	45

i Další technické parametry jsou k dispozici na našich internetových stránkách.