





Pneumatic swing clamp cylinders are used for various types of clamping. Thanks to the design, it is easy to fit the clamping material because the clamping arm rotates over the material during clamping and then clamps. The angle of rotation is 90° as standard. With the double-sided arm, it is possible to clamp the material on two opposite sides at the same time. The clamps have a magnetic piston for contactless position sensing and do not have cushioning at the end positions. The single-sided clamping arm can be turned to any position, the double-sided arm has a fixed position.

Working pressure	0,6 MPa
Min. pressure	0,1 MPa
Max. pressure	1,0 MPa
Temp. range	-5°C to +60°C
Working medium	modified compressed air

Piston diameter [mm]	32	40	50	63
Thrust at 0.6 MPa [N]	482	754	1178	1870
Return (clamp) force at 0.6 MPa [N]	360	630	980	1680
Total stroke [mm]	26	26	30	30
Clamp stroke (linear movement only) [mm]	13	13	13	13
Stroke during swing [mm]	13	13	17	17
Non-rotating accuracy [°]	±2	±1,3	±1,2	
Available speed range [mm.s ⁻¹]	50 - 200			
Port size	G1/8"	G1/8"	G1/8"	G1/8"
Weight - without arm / single sided arm / double sided arm [kg]	0,45 / 0,65 / 0,85	0,61 / 0,83 / 1,00	0,95 / 1,33 / 1,67	1,24 / 1,66 / 1,95

Order codes

18001 11 1 2 050 0090

Clamping arm	
0	without arm (with piston rod end for single side arm)
1	single-sided 
2	double-sided 

Rotation	
1	clockwise „R“
2	counterclockwise „L“

Piston diameter	
032	32 mm
040	40 mm
050	50 mm
063	63 mm

Rotation angle / repair kit	
0090	rotation angle 90°
9999	repair kit

Rotation

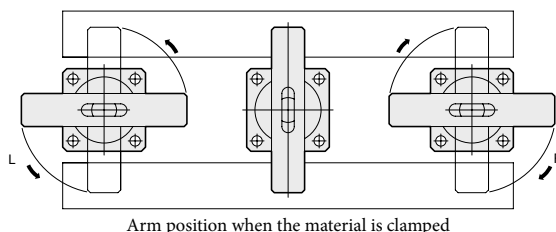
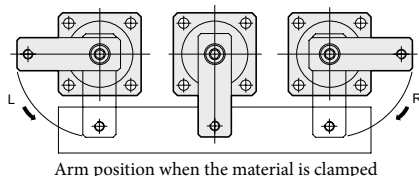
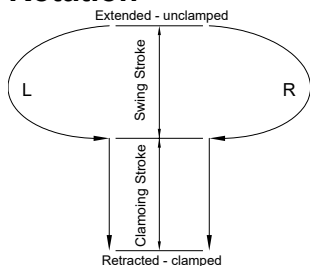

Construction / materials

- body, end cap: dural, anodized
- piston rod: CK45
- arm: steel, zinc plated



In case of proximity sensing request, please use switches series KT-50 or RZT7/MZT8 - see page 3-2 and 3-4 for details

Dimensions

Clamp with single-sided arm

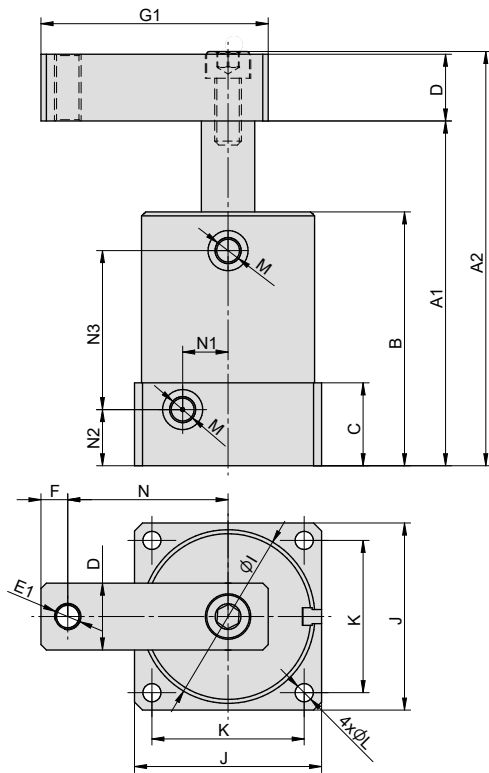

Piston rod end detail for single-sided arm and for version without arm:

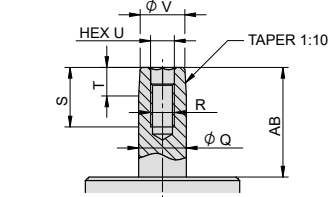

Piston rod end detail for double-sided arm:

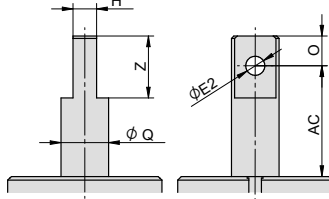

Clamp with double-sided arm

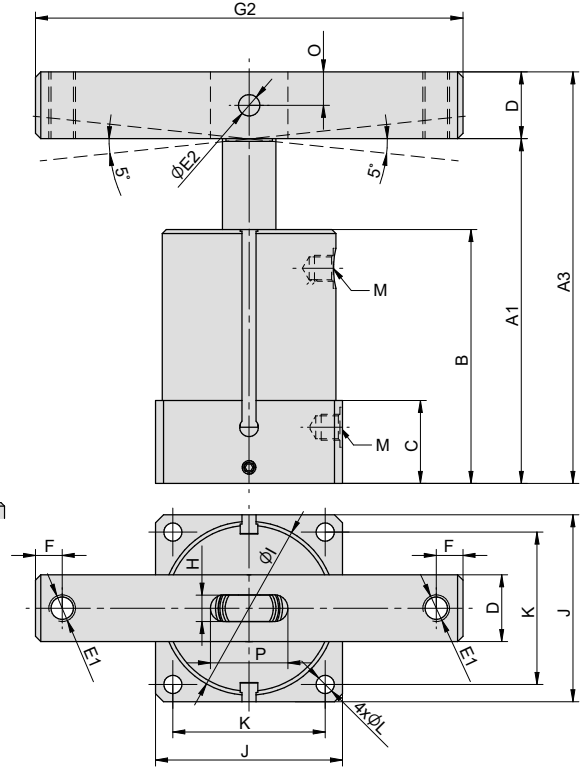

Ø	A1	A2	A3	AB	AC	B	C	D	E1	E2	F	G1	G2	H	I	J
32	113	134	133	39,5	40	83	28	20	M8	8	8	70	140	9	46	50
40	115	136	135	39,5	40	85	28	20	M8	8	8	75	140	9	55	60
50	129	155	154	46	46,5	95	31	25	M10	8	10	85	160	10	65	70
63	129	155	154	46	46,5	95	31	25	M10	8	10	95	160	10	78	83

Ø	K	L	M	N	N1	N2	N3	O	P	Q	R	S	T	U	V	Z
32	40	5,6	G1/8"	50	11,5	19	55	10	25	16	M8	20	9,5	8	15,1	21
40	48	6,8	G1/8"	55	14	19	57	10	25	16	M8	20	9,5	8	15,1	21
50	57	6,8	G1/8"	60	17	21	59,5	12,5	29	20	M10	25	12	10	18,7	26
63	67	9	G1/8"	70	20	21	59,5	12,5	29	20	M10	25	12	10	18,7	26



Caution

Do not allow lateral forces to act on the clamping arm. It could cause irreversible damage to the internal parts. The clamp is designed for clamping forces in the direction of the clamp axis (in the direction of the clamping stroke).



Caution

In order to avoid shocks in end positions (and thereby reduce the service life or damage internal parts), it is necessary to use flow control valves for both directions of movement.

Loosening, fixing, rotating or replacing the clamping arm

When loosening or fastening the arm, it is necessary to secure it in the desired position. Never tighten the locking screw without securing the clamping arm. Torque transferred to the piston rod could damage internal parts.

After unscrewing the fixing screw, tap your arm in the direction of the axis of the clamp. Do not release it by tapping it from the side, it could damage the internal parts.

