



Air cannon is used to give support to free-flow of material in bunkers, hoppers, silos, etc. The volume of reservoir of air cannon is intensely expanded into the area with blocked material. This shot will release the material, which will flow by standard way.

Working pressure	0,6 MPa
Min. pressure	0,2 MPa
Max. pressure	0,6 MPa, 1,0 MPa for 35, 50, 70 l
Temp. range	-25°C to +90°C
Working medium	modified compressed air

Size - volume	2 liters	8 liters	35 liters	50 liters	70 liters
Connections	G3/8"	G1/2"	G1/2"	G1/2"	G1/2"
Weight [kg]	10	33	59	76	77
Min. tightening torque [Nm]	25	100	100		
Recommended orifice of air supply [mm]	8	8	8 (12 for external pressure vessel filling)		
Recommended flow capacity [Nl/min]	600	600	600 (2600 for external pressure vessel filling)		
Max. number of shots per minute	10	6	1 (10 with external pressure vessel filling)		
Flange connection	DN20 PN6	DN50 PN16	DN100 PN16		

Order codes

Size - volume	Order codes
Air cannon, volume 2 liters	4500 2608 4406 0002
Air cannon, volume 8 liters	4500 2608 4406 0001
Air cannon, volume 35 liters	4500 2608 4406 0006
Air cannon, volume 50 liters	4500 2608 4406 0005
Air cannon, volume 70 liters	4500 2608 4406 0007

Installation and operation notes

We recommend to fix fixing screws with Loctite 242E or similar adhesive.

There is necessary to check right tightening of fixing screws regularly to prevent their releasing.

The quick exhaust valve is included in delivery, compressed air should be connected to the quick exhaust valve.

The air cannon must be fixed by restraining cable to the vessel.

Installation must be done accordingly to the users manual.



Warning

Detailed information regarding the connection, installation and operation of the cannon is given in the instruction manual of the device. You can find this manual at www.sappv.cz/r/w05e, or you can request it from the sales or technical department of Stránský a Petržík.

Construction / materials Type 2 liters and 8 liters

- body, end cap: steel, zinc plated
- tube: extruded dural tube
- piston: plastic
- sealing: NBR

Type 35, 50 and 70 liters

- body, tube, end cap: steel, zinc plated (weldment)
- piston: POM
- sealing: NBR
- pressure vessel attached with a flange connection



As an accessory to the cannon, it is possible to supply a force blowing nozzle with the possibility of adjusting the angle of the spiral air flow, which will help direct the air in the required direction. More on the following pages.

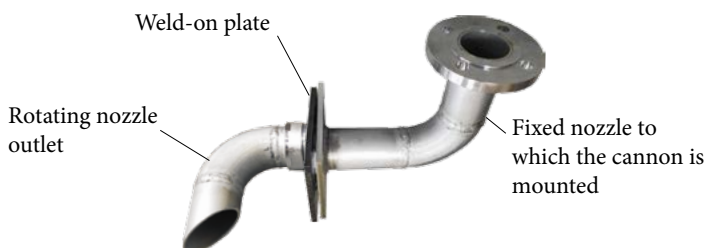

Dimensions

Type 2, 8, 35 and 70 liters

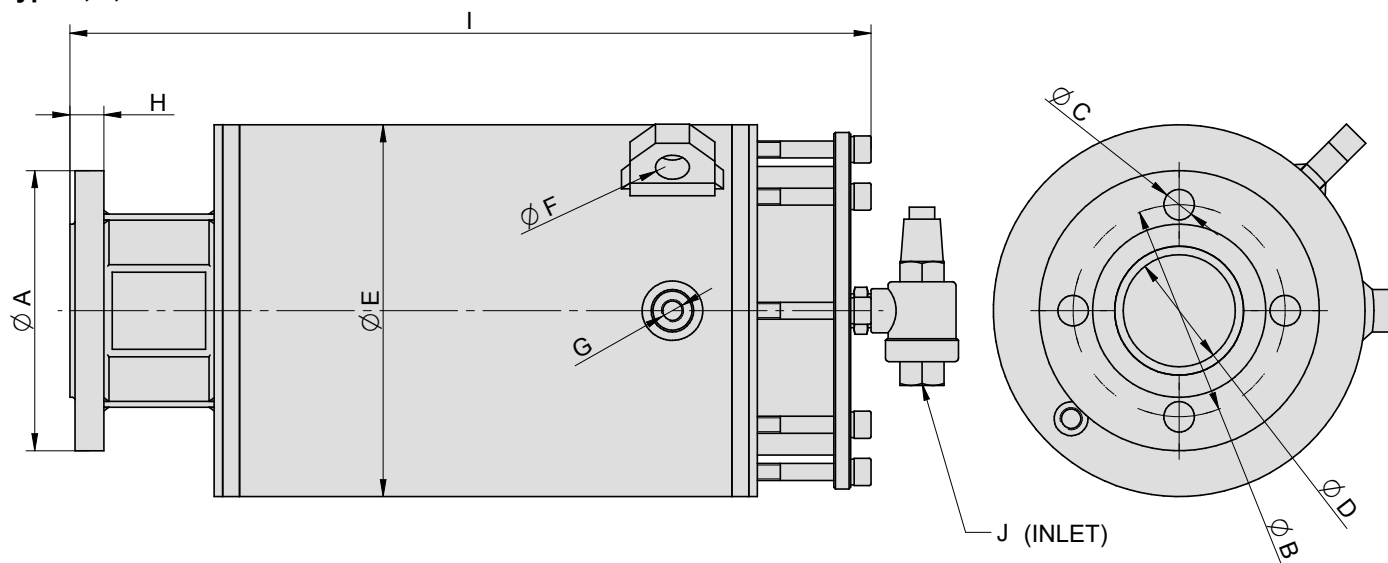

Volume	A	B	C	D	E	F	G	H	I	J
2 liters	90	65	4x $\varnothing 11$	20	133	12	G1/4"	14	367	G3/8"
8 liters	165	125	4x $\varnothing 18$	66	219	20	G1/4"	20	472	G1/2"
35 liters	215	180	8x $\varnothing 18$	100	400	40	G1/2"	25	668	G1/2"
70 liters	215	180	8x $\varnothing 18$	100	500	40	G1/2"	25	753	G1/2"

Type 50 liters

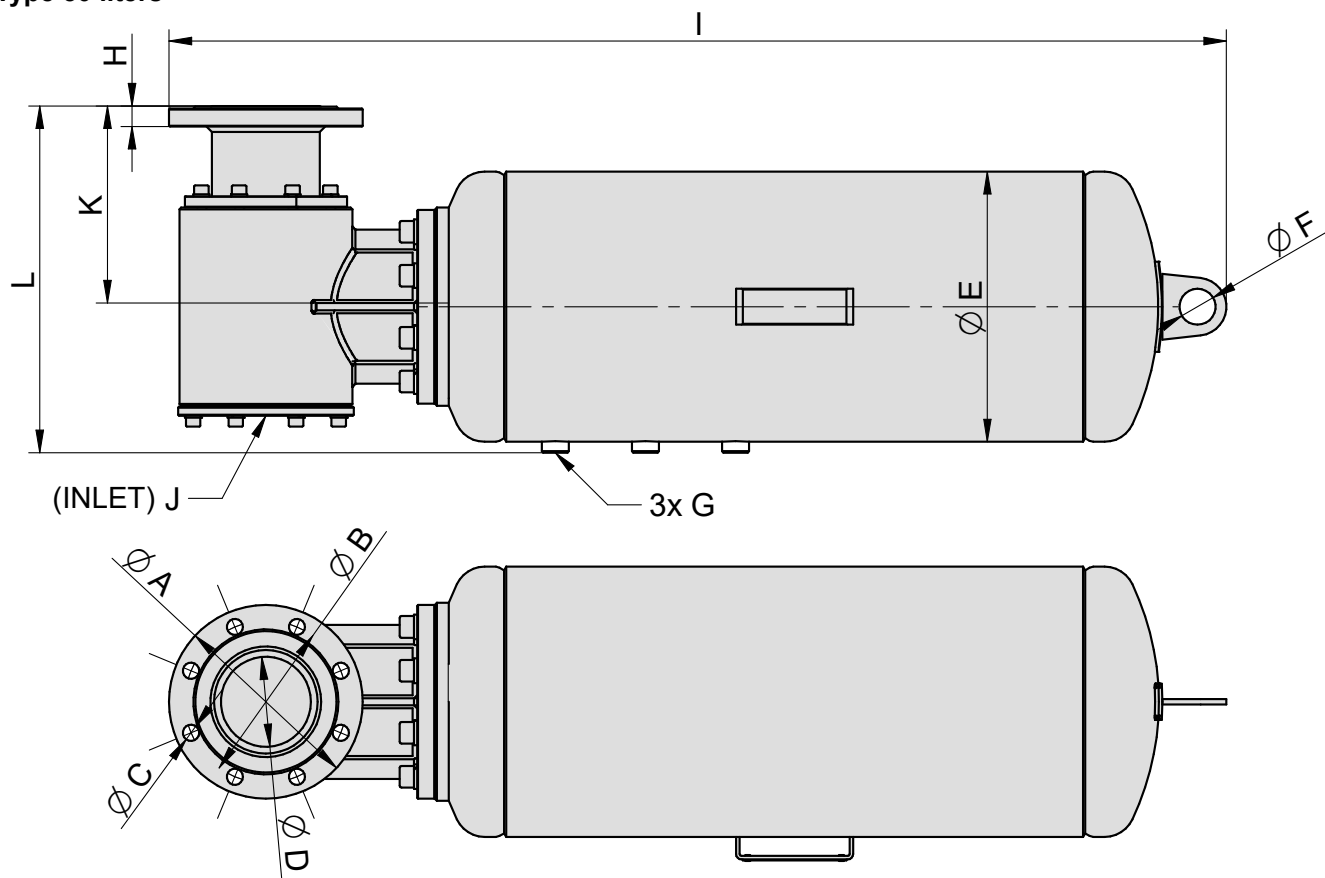

Volume	A	B	C	D	E	F	G	H	I	J	K	L
50 litres	215	180	8x $\varnothing 18$	100	300	40	G1/2"	23	1175	G1/2"	219	385

Accessories

Fixed nozzle

The fixed nozzle is used to connect the cannon to the hopper, to which the weld-on plate is welded (see below). If it is not necessary to direct the air in the hopper, it can be used separately. If it is necessary to direct the air in the hopper, a rotating nozzle is screwed onto the thread (G) and fixed (see below). It is supplied as a complete set including seals and screws required for connection to the gun. Material: zinc plated steel.

For cannons with a volume of 2 and 8 liters

For cannon with a volume of 35, 50 and 70 liters:

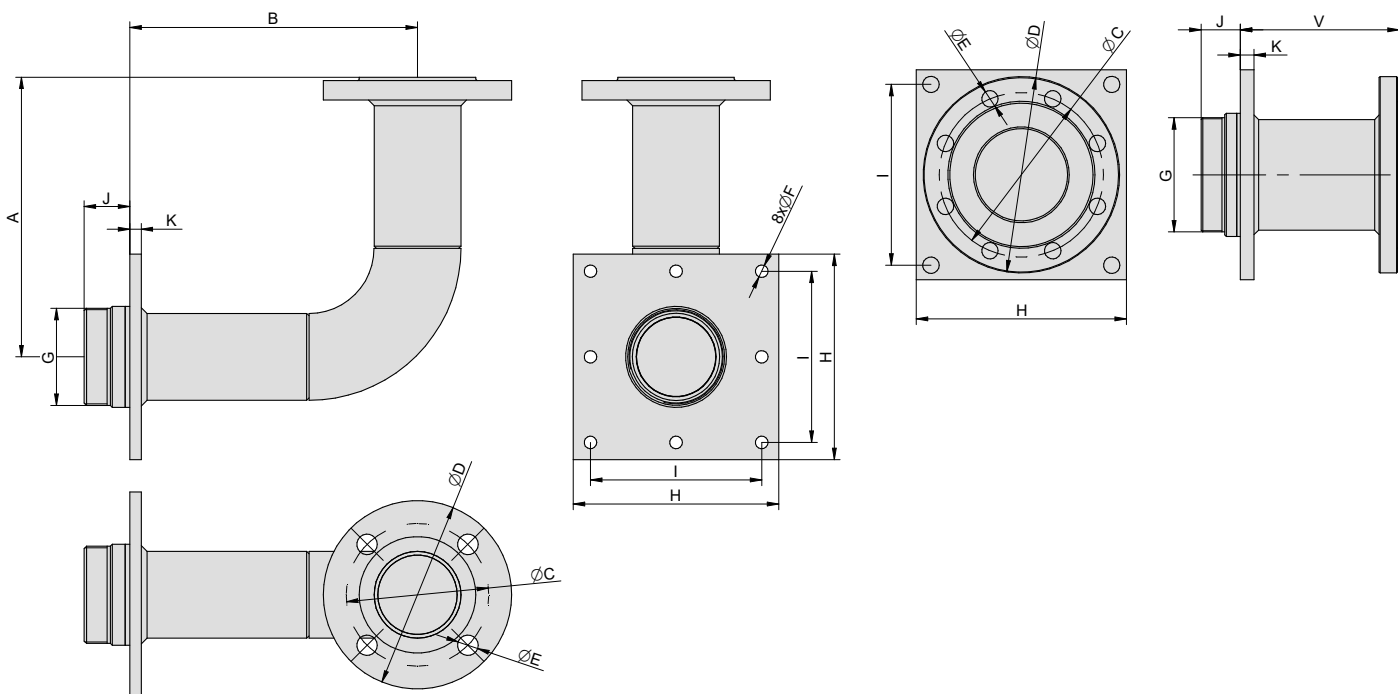

Volume	A	B	C	D	E	F	G	H	I	J	K	V	Weight	Order codes
2 liters	89	112	65	90	11	9	M35x1,5	120	100	22	10	-	2,04	9700 0030 9010 1000
8 liters	245	252	125	165	18	11	M85x2	180	150	40	10	-	8,35	9700 0030 8010 1000
35, 50 and 70 liters	-	-	180	215	18	18	M125x2	230	198	43	15	174	14,50	9700 0083 6010 1000

Rotating nozzle

The rotating nozzle is screwed and fixed to the outlet of the fixed nozzle in the hopper. Thanks to it, it is possible to direct the air flow in the desired direction. Material: zinc plated steel.

Weld-on plate

The plate is welded to the hopper and the fixed nozzle is screwed to this plate. It is necessary to create a hole in the hopper larger than $\varnothing L$. It is supplied as a complete set including the gasket and screws required for connection to the fixed nozzle. Material: steel without surface treatment.

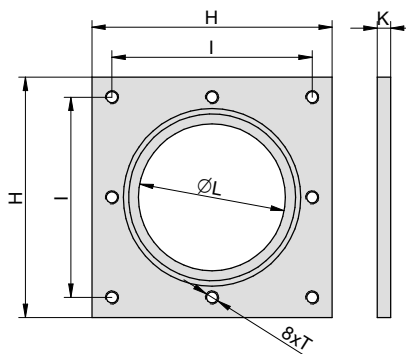
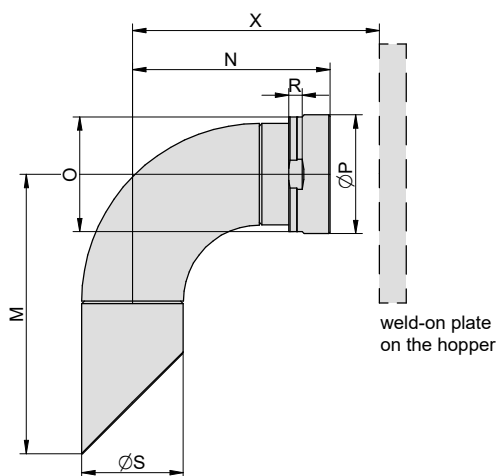

Volume	M	N	O	P	R	S	Weight	Order codes
2 liters	72	74	36	39	8	28	0,24	9700 0030 9010 2000
8 liters	209	148	86	89	10	76	2,06	9700 0030 8010 2000
35, 50, 70 l	317	210	130	135	15	114	5,20	9700 0083 6010 2000

Volume	H	I	K	L	T	Weight	Order codes
2 liters	120	100	10	60	M8	0,95	9700 0030 9010 1006
8 liters	180	150	10	110	M10	1,91	9700 0030 8010 1006
35, 50, 70 l	230	198	15	160	M16	5,00	9700 0083 6010 1006

**Accessories
Blanking plate**

The blanking plate is used to protect the opening in the fixed nozzle when there is a time delay between preparing the hopper and installing the cannon, or after removing the cannon. It prevents foreign objects or moisture from entering the hopper. It is supplied as a complete set including the screws required for connection to the fixed nozzle. Material: zinc plated steel.

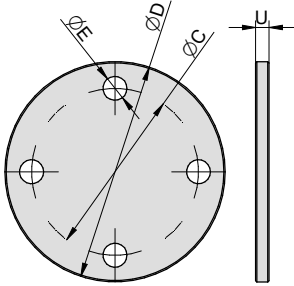

Volume	C	D	E	U	Weight	Order codes
2 liters	65	90	11	6	0,49	9700 0030 9010 1005
8 liters	125	165	18	10	2,64	9700 0030 8010 1007
35, 50, 70 liters	180	215	18	10	3,82	9700 0083 6010 1007

Recommended connection

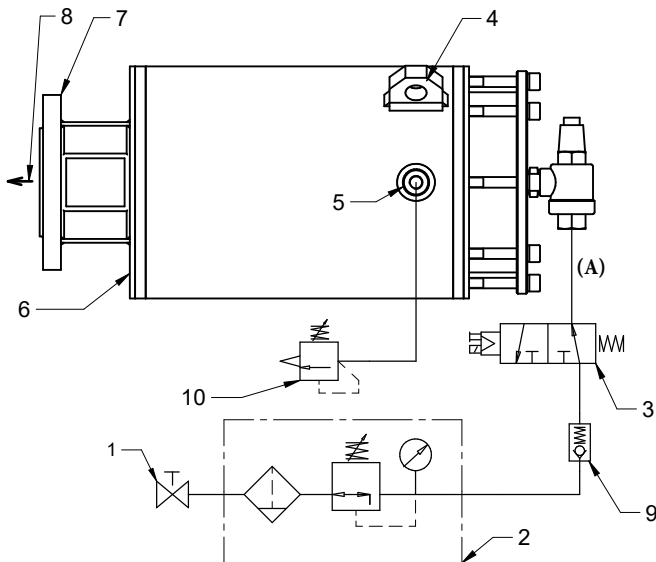

The 3/2 valve is suitable for air cannon control. We recommend to mount the valve outside, where the air cannon's shocks couldn't reach the valve.

Position	Description
1*	shutting-off valve
2*	filter with pressure regulator
3*	3/2 normally open valve
4	shackle for installing restraining cable
5	plug G1/4" - for example for gauge
6	draining screw
7	flange connection
8	direction of air shot
9*	reverse throttle valve
10*	safety valve

Items marked by asterisk (*) are optional - they have to be ordered separately.

(A) We recommend consulting the choice of length and diameter of the marked parts of the circuit with our technical department.

Mounting examples

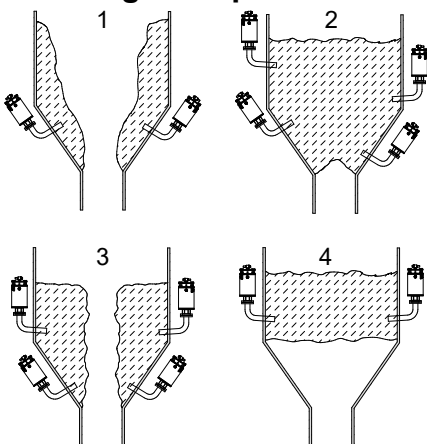

There are four main problems associated with interruption of free flow of bulk solids in bunkers, hoppers, silos transfer chutes etc., as shown in Figs. 1, 2, 3 and 4. Please note these illustrations are for general information only, there being various other blocking scenarios which occur

- 1) Clinging
Material deposits clinging to the sides of hoppers, reducing free-flow and creating the possibility of contamination of new material if clinging deposits break free from sides of vessel.
- 2) Bridging
Blockage at the outlet of the storage hopper resulting in complete loss of production. This is a common fault where fine materials are being processed and the moisture content is higher than normal.
- 3) Ratholing
An extreme form of clinging, reducing free-flow and requiring regular topping up of small quantities of material. Loss of production will be the result of this condition and the solution, i.e., high pressure lancing vibration etc., can result in huge lumps of material breaking away and blocking the outlet.
- 4) Arching
Type of bridging occurring at a high level within the hopper. This condition creates a dangerous situation for operators when trying to clear the blockage and also a possible maintenance /damage issue for the works engineer and the high costs resulting from the loss of production.