

# DOUBLE ACTING PNEUMATIC TELESCOPIC CYLINDERS SERIES RT



Double-acting RT series actuators consist of 2 or 3 stages, providing strokes significantly exceeding the cylinder's overall length. They are ideal for space-constrained applications where standard cylinders cannot be used, offering 50–60% space savings. For optimal service life, a vertical mounting position is recommended; otherwise, lower maximum strokes and speeds must be expected. Cylinders must not be exposed to side loads or torsional moments and are not suitable for dusty or abrasive environments. Operating force is limited by the smallest piston area. Stages and the piston rod are non-rotating as standard, with a rotating rod version available as an option.



Working pressure	0,6 MPa
Min. pressure	0,15 MPa
Max. pressure	1,0 MPa
Temp. range	-20°C to +80°C
Working medium	modified compressed air

Stages	2					3		
Piston diameter [mm]	25	32	40	50	63	40	50	63
Internal stage diameters [mm]	16	20	25	32	40	25 + 16	32 + 20	40 + 25
Thrust at 0,6 MPa [N]	123	192	300	492	769	123	192	300
Return force at 0,6 MPa [N]	65	123	231	369	649	65	123	231
Connection	M5	G1/8"	G1/8"	G1/8"	G1/8"	G1/8"	G1/8"	G1/8"
Maximum stroke [mm] in vertical position	300	400	600	900	1200	1200	1500	1800
Maximum stroke [mm] in horizontal position	150	200	300	450	600	600	750	900
Working speed [mm/s]	500							
Stroke tolerance [mm]	+2,0	+3,2	+3,2	+3,2	+3,2	+4,0	+4,0	+4,0
Max. torque on non-rotating piston rod [Nm]	0,5	0,8	1,0	2,0	3,0	0,5	0,8	1,0

## Order codes

ART 2 2 0 032 0600 L

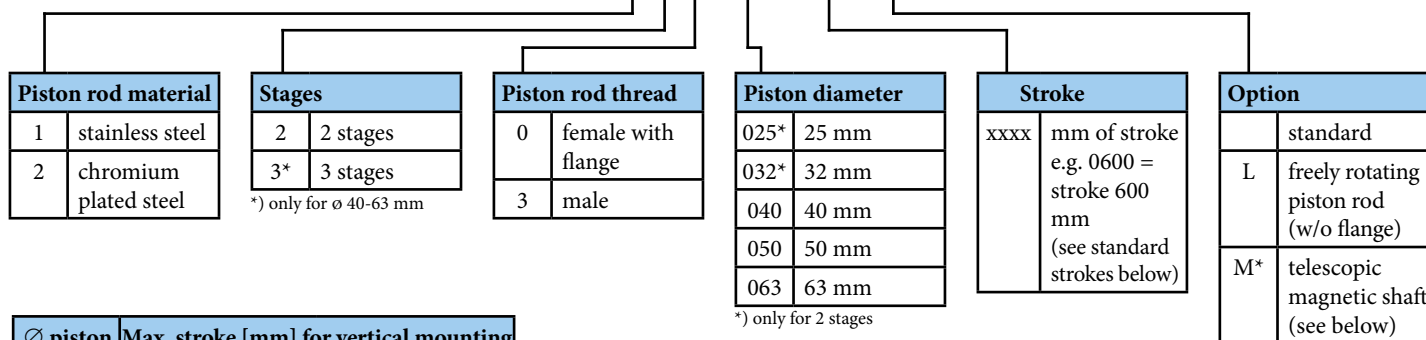

Ø piston [mm]	Max. stroke [mm] for vertical mounting	
	2 stages	3 stages
25	300	—
32	400	—
40	600	1200
50	900	1500
63	1200	1800

Stages	Standard strokes [mm]*
2	100, 120, 160, 180, 200, 300, 400, 500, 600, 700, 800, 900, 1000, 1100, 1200
3	150, 180, 210, 240, 270, 300, 360, 450, 600, 750, 900, 1050, 1200, 1500, 1800

Note: Max. stroke is reduced by 50% for non-vertical positions.

\*) Other strokes are possible; must be a multiple of the number of stages.

## Construction / materials

- caps: die-cast aluminium
- tube: drawn dural profile, anodized
- guide slide: POM
- piston rod: grounded round steel bar with hard chrome plated surface (optional stainless steel)
- seals and bumpers: NBR



The first-stage piston is magnetic as standard, but due to cylinder design, only the fully retracted position can be reliably sensed. With the optional telescopic magnetic shaft (option „M“), both end positions—fully retracted and fully extended—can be monitored. Intermediate position sensing is not possible.



## Warning

- Optimal performance requires axial loading in a vertical position. Otherwise, the following restrictions apply:
- max. stroke reduced by 50 %
  - use cylinders with slide units
  - no radial loads on telescopic stages
  - max. speed 0,5 m/s.

**Dimensions**

2 stages, female thread on piston rod with flange, type RT220...

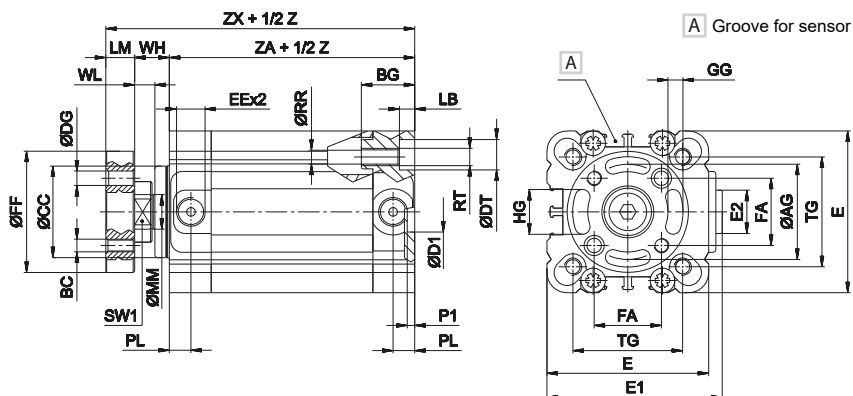

2 stages, female thread on piston rod with flange, with telescopic magnetic shaft, type RT220...M

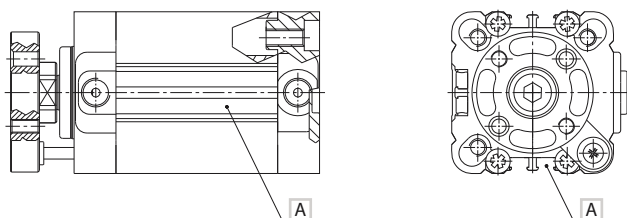

A Sensor must be placed in the groove closest to the telescopic magnetic shaft

2 stages, male thread on piston rod, type RT223...

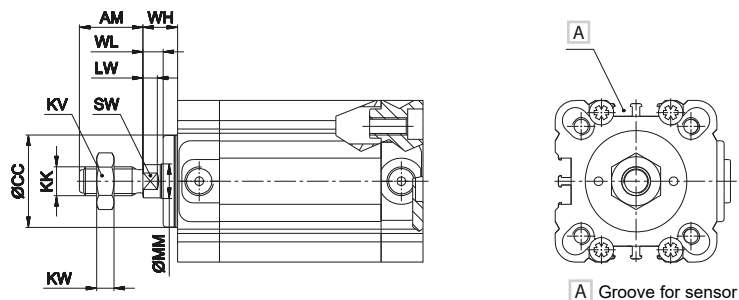

A Groove for sensor

Z = cylinder stroke

∅	AG	AM	BC	BG	CC	DG	DT	D1	E	E1	E2	EE	FA	FF	GG	HG	KK
25	22	22	M5	16	22	5	8	2	37	39	18	M5	15,6	30	5	9	M10x1,25
32	28	22	M5	18	26	5	9	14	46	50,5	16	G1/8"	19,8	37	5,2	11	M10x1,25
40	33	22	M5	18	32	5	9	14	56	60,5	16	G1/8"	23,3	42	5,2	15	M10x1,25
50	42	24	M6	24	40	6	11	18	66	70,5	16	G1/8"	29,7	52	6,2	19	M12x1,25
63	50	24	M6	24	48	6	11	18	79	83,5	38	G1/8"	35,4	64	6,2	25	M12x1,25

∅	KV	KW	LB	LM	LW	MM	PL	P1	RR	RT	SW	SW1	TG	WH	WL	ZA	ZX
25	17	3	4,5	8	4,5	10	8	8	4,2	M5	8	—	26	17	7	48	73
32	17	4	5,3	10	5	12	7,5	2,5	5,2	M6	10	17	32,5	13	7	58	81
40	17	4	5,3	10	5	12	7,5	2,5	5,2	M6	10	19	38	12	7	60	82
50	19	5	6,5	12	6	16	7,5	2,5	6,6	M8	13	24	46,5	15	8	61	88
63	19	5	6,5	12	6	16	7,5	2,5	6,6	M8	13	24	56,5	15	8	65	92

Type	RT220...					RT220...M					RT223...				
Piston diameter [mm]	25	32	40	50	63	25	32	40	50	63	25	32	40	50	63
Weight 0 mm stroke [kg]	0,307	0,377	0,559	0,911	1,393	-	0,392	0,568	0,917	1,402	0,310	0,380	0,537	0,876	1,300
Weight add. per 100 mm stroke [kg]	0,152	0,219	0,267	0,386	0,451	-	0,220	0,268	0,387	0,452	0,152	0,219	0,267	0,386	0,451

# DOUBLE ACTING PNEUMATIC TELESCOPIC CYLINDERS SERIES RT

## Dimensions

3 stages, female thread on piston rod with flange, type RT230...

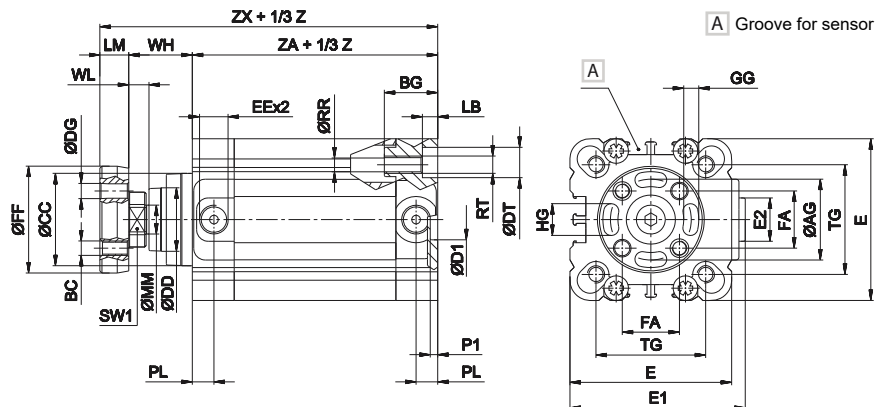

3 stages, female thread on piston rod with flange, with telescopic magnetic shaft, type RT230...M

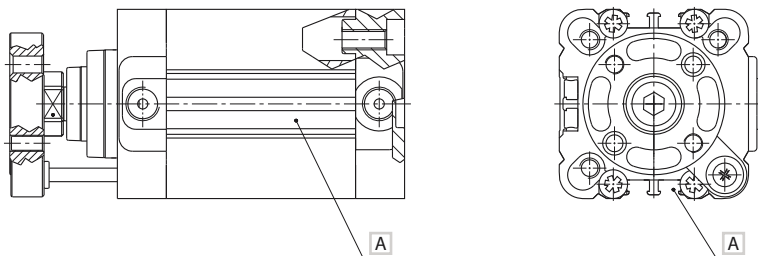

A Sensor must be placed in the groove closest to the telescopic magnetic shaft

Other dimensions - see below

Ø	BC	DG	FA	FF	LM	SW1	ZX
40	M5	5	23,3	42	10	19	92
50	M6	6	29,7	52	12	24	97
63	M6	6	35,4	64	12	24	102

3 stages, male thread on piston rod, type RT233...

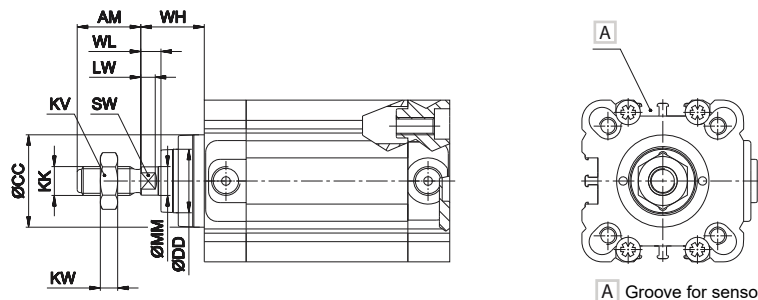

Z = cylinder stroke







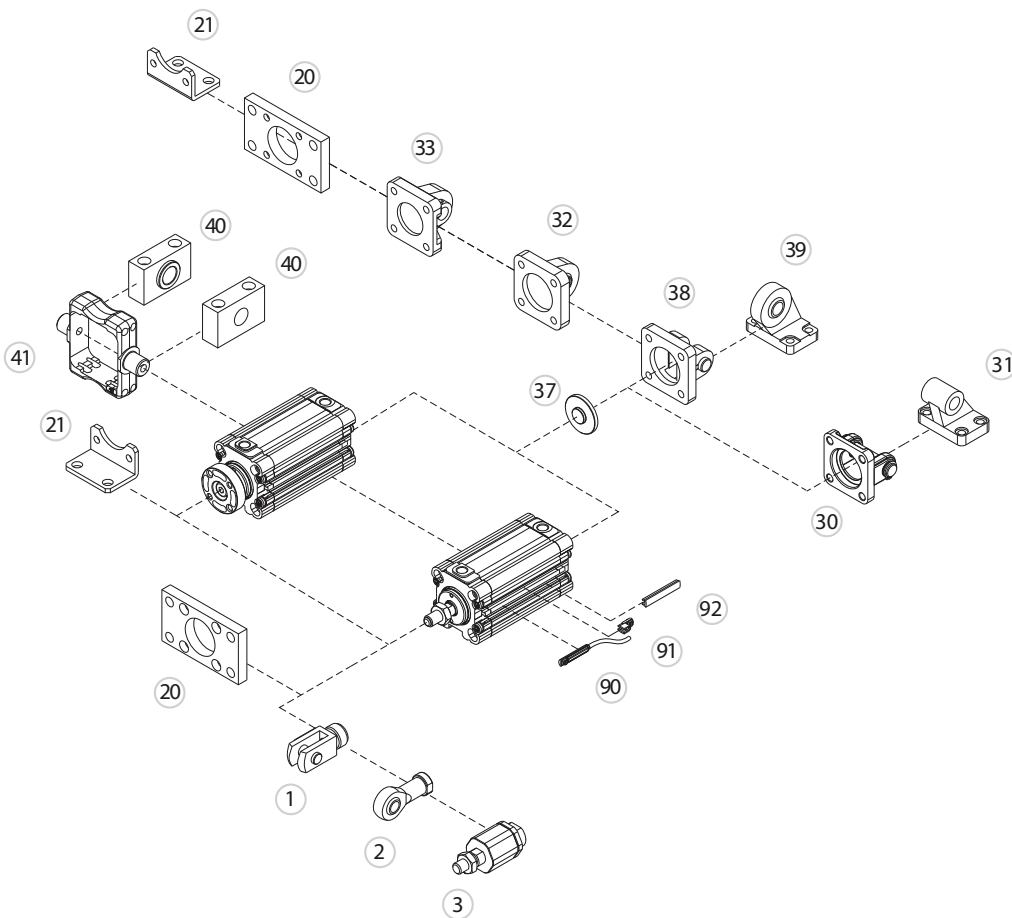

Ø	AG	AM	BC	BG	CC	DG	DT	D1	E	E1	E2	EE	FA	FF	GG	HG	KK
40	33	22	M5	18	32	5	9	14	56	60,5	16	G1/8"	19,8	37	5,2	15	M10x1,25
50	42	24	M5	24	40	5	11	18	66	70,5	16	G1/8"	19,8	37	6,2	19	M10x1,25
63	50	24	M5	24	48	5	11	18	79	83,5	38	G1/8"	23,3	42	6,2	25	M10x1,25

Ø	KV	KW	LB	LM	LW	MM	PL	P1	RR	RT	SW	SW1	TG	WH	WL	ZA	ZX
40	17	4	5,3	10	5	10	7,5	2,5	5,2	M6	10	17	38	22	7	60	92
50	19	5	6,5	10	6	12	7,5	2,5	6,6	M8	13	17	46,5	24	7	61	95
63	19	5	6,5	10	6	12	7,5	2,5	6,6	M8	13	19	56,5	25	7	65	100

Type	RT230...			RT230...M			RT233...		
Piston diameter [mm]	40	50	63	40	50	63	40	50	63
Weight 0 mm stroke [kg]	0,529	0,775	1,027	0,560	0,819	1,271	0,530	0,768	1,190
Weight add. per 100 mm stroke [kg]	0,281	0,366	0,452	0,283	0,368	0,454	0,281	0,366	0,452

**Mounting accessories**



Mounting accessories ... see page	
1	Piston rod clevis ... 4-2
2	Piston rod eye ... 4-3
3	Self-aligning piston rod coupling ... 4-3
20	Flange mounting ... 4-5
21	Foot mounting ... 4-5
30	Swivel flange ... 4-7
31	Clevis foot mounting ... 4-7
32	Swivel flange with spherical bearing ... 4-8
33	Swivel flange 
37	Centering adaptor ring 
38	Narrow swivel flange ... 4-9
39	Swivel flange 
40	Trunnion mounting 
41	Pivot pin 
90	Sensor 
91	Cable clamping 
92	Covering strip 

**Dimension comparison**

**i** With 2-stage telescopic cylinders, up to 50% of installation space can be saved compared to standard cylinders according to ISO 15552 or VDMA 24562, while maintaining the same stroke (A). For 3-stage telescopic cylinders, the savings can reach up to 60%.

