

DOUBLE ACTING PNEUMATIC CYLINDERS DIN ISO 6431, VDMA 24562



STRÁNSKÝ A PETRŽÍK



Cylinders are designed to meet the specifications of international standards ISO 6431, VDMA 24562 and NF E 49003.1, that is why it can replace pneumatic cylinder, which is made by any producer to these standards. The cylinders can work in higher temperatures by request. Fully adjustable cushioning at end of stroke is available. The cylinders can be delivered in explosion proof version (Ex), see details in ATEX options).

Working pressure	0,6 MPa
Min. pressure	0,15 MPa
Max. pressure	1,0 MPa
Temp. range	-30°C to +80°C *
Working medium	modified compressed air

*) values are valid for standard gaskets

Piston diameter [mm]	32	40	50	63	80	100	125	160	200	250	320	400
Thrust at 0,6 MPa [N]	482	754	1178	1870	3015	4713	7363	12064	18849	29460	48254	75398
Thrust at 0,6 MPa [N] with double ended piston rod	415	633	990	1682	2720	4418	6880	11581	18096	28274	46384	71657
Return force at 0,6 MPa [N]	415	633	990	1682	2720	4418	6880	11581	18096	28274	46384	71657
Connection	G1/8"	G1/4"	G1/4"	G3/8"	G3/8"	G1/2"	G1/2"	G3/4"	G3/4"	G1"	G1"	G1"
Length of adjustable cushioning [mm]	13	13	11	16	16	20	25	27	32	40	48	48
Max. stroke [mm] *	1000*	1000*	1000*	1000*	1500*	1500*	2000*	2000*	2000*	2000*	2000*	1500*
Weight 0 mm stroke [kg]	0,54	0,80	1,10	1,70	2,70	4,20	7,60	13,30	20,50	29,00	69,50	120,00
Weight add. per 1 mm stroke [kg]	0,0028	0,0037	0,0060	0,0062	0,0100	0,0110	0,0160	0,0280	0,0300	0,0340	0,0650	0,113
Weight 0 mm stroke [kg] with double ended piston rod	0,64	0,90	1,30	1,90	3,40	5,00	9,40	16,30	22,50	33,00	74,00	129,00
Weight add. per 1 mm stroke [kg] with double ended piston rod	0,0038	0,0047	0,0080	0,0082	0,0140	0,0150	0,0220	0,0400	0,0420	0,0460	0,0810	0,137

*) Stroke of cylinder may be longer after agreement with our technical dept.

Order codes

10101 60 00 050 0100

Type	Equipment	Options	Piston diameter
10101 DIN ISO 6431, VDMA 24562, NF E 49003.1, double acting	00 w/o cushioning, w/o magnet 05 with double ended piston rod, w/o cushioning, w/o magnet 10 w/o cushioning, with magnet 15 with double ended piston rod, w/o cushioning, with magnet 50 with cushioning, w/o magnet 55 with double ended piston rod, with cushioning, w/o magnet 60 with cushioning, with magnet 65 with double ended piston rod, with cushioning, with magnet	00 without options 05* all parts stainless steel, piston rod 1.4401 10 Viton® piston rod sealing 11 Viton® gaskets (up to 180°C) 13* tie rod version with round tube 14 1.4301 stainless steel piston rod 16 steel parts from stainless 1.4301 piston rod stainless 1.4401 37 composite round tube+opt. 10 and 16 42 ATEX, Ex II-/2 G Ex h IIC T6 -/Gb Ex II-/2 D Ex h IIC T85°C -/Db 43 piston rod seal with higher resistance in dusty environments 44 composite round tube+opt. 5 and 10	032 32 mm 040 40 mm 050 50 mm 063 63 mm 080 80 mm 100 100 mm 125 125 mm 160 160 mm 200 200 mm 250 250 mm 320 320 mm 400 400 mm

Stroke / Repair kit	
xxxx	mm of stroke e.g.: 0100 = stroke 100 mm
9999	repair kit

Construction / materials

- caps: drawn dural profile, anodised, piston dia. 100 and more: aluminium casting, anodised
- body: drawn dural profile, anodized, piston dia. 125 and more: drawn dural tube, anodized, piston dia. 400: steel or composite sandwich plastic
- piston rod: grounded round steel bar CK45 with hard chrome plated surface

For more options regarding materials or dimensions, please contact our technical dept.

*) For piston dia. 32 to 100 incl.

Dimensions

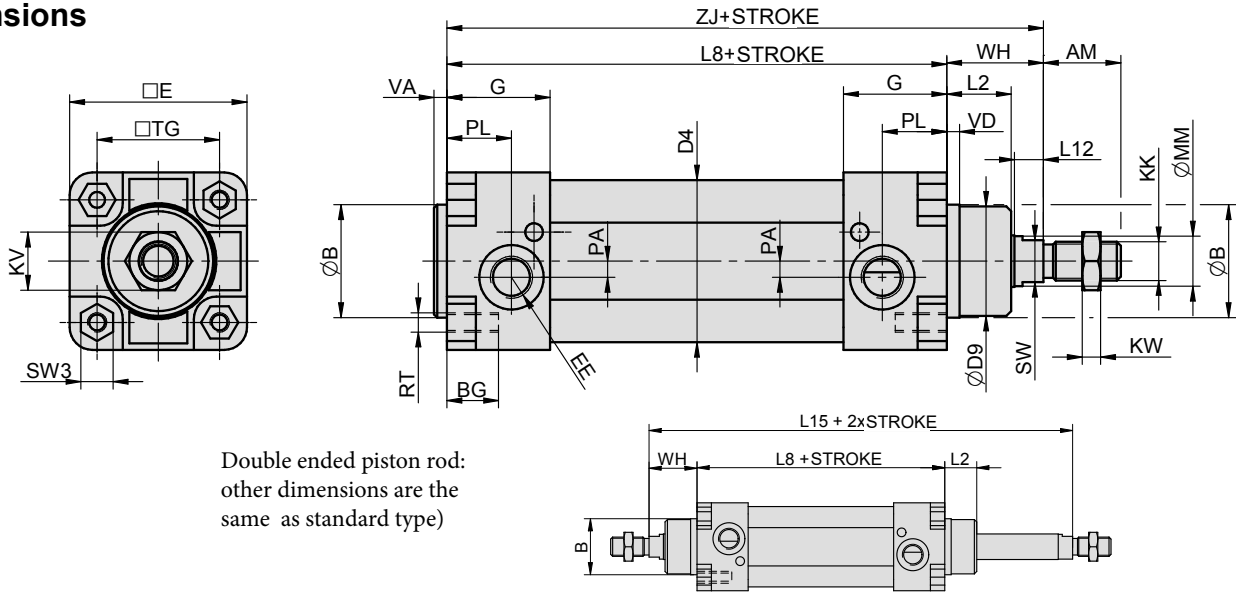

Double ended piston rod:
other dimensions are the
same as standard type)

Ø	AM	B	BG	D4	D9	E	EE	G	KK	KV	KW	L2	L8	L12	L15	MM	PA	PL	RT	SW	SW3	TG	VA	VD	WH	ZJ
32	22	30	16	36	28	48	G1/8"	31,5	M10x1,25	17	6	18	94	8	146	12	5	22,5	M6	10	10	32,5	4	4	26	120
40	24	35	16	45	34	55	G1/4"	32	M12x1,25	19	10	20	105	9	165	16	5	20	M6	13	10	38	4	4	30	135
50	32	40	19	55	39	65	G1/4"	30	M16x1,5	24	8	22	106	10	180	20	3	17	M8	16	14	46,5	4	5	37	143
63	32	45	19	68	44	75	G3/8"	30	M16x1,5	24	8	23	121	10	195	20	6	16	M8	16	14	56,5	4	5	37	158
80	40	45	19	86	44	94	G3/8"	30	M20x1,5	30	9	31	128	10	220	25	10	16	M10	21	17	72	4	5	46	174
100	40	55	19	106	54	115	G1/2"	36	M20x1,5	30	9	34	138	10	240	25	11	18	M10	21	17	89	4	17	51	189
125	54	60	20	132	58	140	G1/2"	40	M27x2	41	12	50	160	14	290	32	11	22	M12	27	22	110	6	6	65	225
160	72	65	24	168	64	185	G3/4"	50	M36x2	55	18	50	180	20	340	40	10	25	M16	36	30	140	6	10	80	260
200	72	75	24	212	74	235	G3/4"	50	M36x2	55	18	55	180	20	370	40	12	25	M16	36	30	175	6	20	95	275
250	84	90	32	262	84	270	G1"	54	M42x2	65	21	76	200	22	410	50	25	32	M20	46	36	220	10	10	105	305
320	96	110	30	340	100	350	G1"	57	M48x2	75	24	85	220	24	560	63	23	32	M24	55	41	270	10	35	120	340
400	96	110	28	420	100	430	G1"	57,5	M48x2	75	24	85	220	26	560	63	25	32	M24	55	41	350	10	35	120	340

Mounting accessories

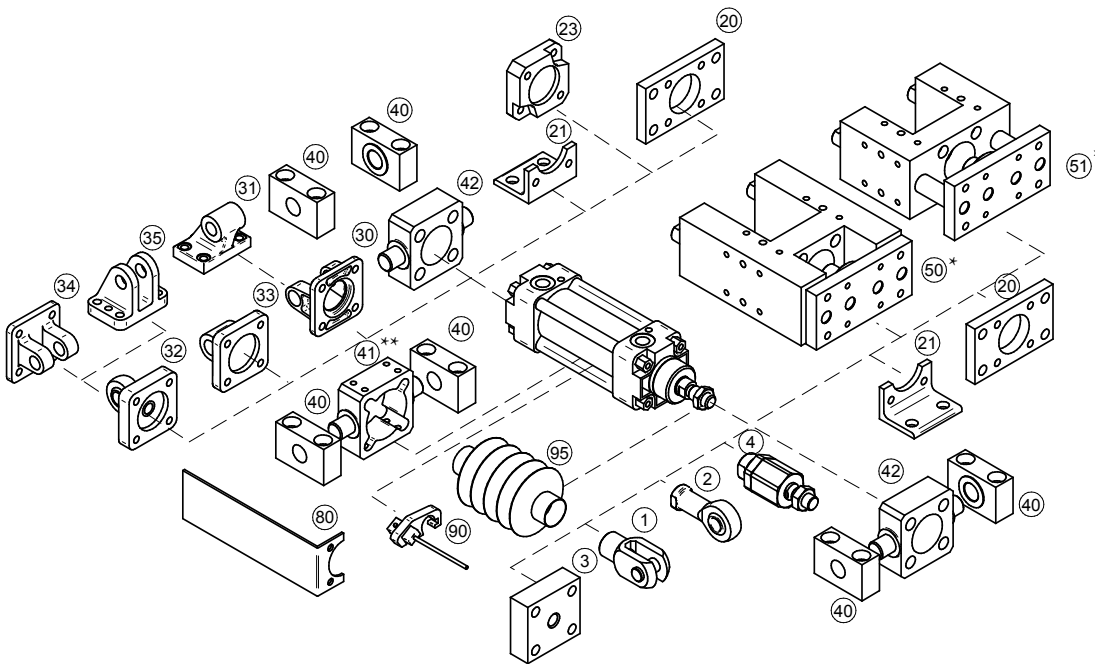

Mounting accessories	... see page
1 Piston rod clevis	... 4-2
2 Piston rod eye	... 4-3
3 Flanged piston rod coupl.	... 4-2
4 Self-align. piston rod coupl.	... 4-3
20 Flange mounting	... 4-5
21 Foot mounting	... 4-5
23 Boxer flange mounting	... 4-6
30 Swivel flange	... 4-7
31 Clevis foot mounting	... 4-7
32 Swivel flange with spherical bearing	... 4-8
33 Swivel flange	... 4-8
34 Narrow swivel flange	... 4-9
35 Rectangular swivel flange	... 4-9
40 Trunnion mounting	... 4-10
41 Pivot pin**	... 4-11
42 Pivot pin to front/end cap	... 4-13
50 Guide unit H with ball bearings*	... 4-14
51 Guide unit with slide bearings*	... 4-16
80 Valve bracket	... 4-13
90 Prox. switch	... 3-2, 3-4, 3-7
95 Piston rod protective cover	... 4-4

*) When guide unit H or U is used on cylinder with magnetic piston, it is necessary to use cylinder with tie rod version (option No. 13).
There is no free space to mount switch bracket near the front cap when the profile tube is used (position for extend piston rod).
)*) Type of pivot pin should be selected accordingly to the cylinder profile/tube - with cutout for profile or for round tube.