

DOUBLE ACTING PNEUMATIC SWING ACTUATORS SERIES ATM



Swing actuators of the ATM series are mainly intended for the control of fittings and valves. The swing movement is ensured by a pair of toothed combs with pistons. The advantage is a constant torque in the range of the entire swinging movement. The actuators have a fitting connection according to ISO

5211 and DIN 3337. The drive is prepared for switchboards and position sensors with connection according to NAMUR VDI/VDE 3845, air can be connected directly to the threaded holes.

Working pressure	0,6 MPa
Min. pressure	0,2 MPa
Max. pressure	0,8 MPa
Temp. range	-20°C to +80°C *
End position regulation	±4°
Working medium	modified compressed air

*) values for temp. range B

Piston diameter [mm]	52	63	75	83	92	105	125	140	160	190	210	240	270	300	350	400
Connection	G1/4"	G1/4"	G1/4"	G1/4"	G1/4"	G1/4"	G1/4"	G1/4"	G1/4"	G1/4"	G1/4"	G1/4"	G1/2"	G1/2"	G1/2"	G1/2"
Air source interface	NAMUR VDI/VDE 3845															
Flange connection pattern 1	F03	F05	F05	F05	F05	F07	F07	F10	F10	-	-	-	-	-	F16	F16
Flange connection pattern 2	F05	F07	F07	F07	F07	F10	F10	F12	F12	F14	F14	F16	F16	F16	F25	F25
Armature connection	ISO 5211															
Position sensing	optical with the option of connecting a sensor, positioner or sensor box															
Connection of position sys.	NAMUR VDI/VDE 3845															
Opening time [s] at 0,8 MPa	0,3	0,4	0,4	0,5	0,6	0,7	0,9	1,2	1,6	2,6	3,3	3,8	4,5			
Closing time [s] at 0,8 MPa	0,4	0,4	0,5	0,6	0,7	0,7	1,1	1,4	1,7	3,1	3,8	4,4	5,3			
Weight [kg]	1,38	2,03	2,85	3,13	4,6	6,8	10,0	13,3	20,2	31,5	47,0	67,6	97,0			

Order codes

ZG-ATM 125 X 90 B AM

Piston diameter		Piston diameter		Swing angle		Temperature range	
052	52 mm	160	160 mm	90	angle 90°	B	-20°C to +80°C
063	63 mm	190	190 mm			D	-40°C to +80°C
075	75 mm	210	210 mm			G	-15°C to +150°C
083	83 mm	240	240 mm				
092	92 mm	270	270 mm				
105	105 mm	300	300 mm				
125	125 mm	350	350 mm				
140	140 mm	400	400 mm				

i The swing direction is standard to the right (clockwise). If you require the opposite swing direction, please contact our technical department.

i Limit switches can be found on page 3-10

Construction / materials

- body: hard anodized extruded aluminum alloy, honed bore
- pistons: Aluminum casting or steel casting
- pinion and cam: steel
- caps: Aluminium casting
- seal: NBR, or FPM or silicone
- fasteners: stainless steel
- position indicator: plastic

Actuator sizing

The recommended safety factor for double-acting swing actuator is 20 to 30% under normal conditions. Example of determining the size of the drive:

The required torque of the fitting is 100 Nm, the torque increased by the safety factor is 100 + 30% of 100 = 130 Nm. At an inlet pressure of 0.5 MPa, it is therefore advisable to choose the ZG-ATM105 actuator.



Notice

The torque caused by the drive must not be greater than the maximum permissible torque specified in ISO 5211 for the specific size of the mounting flange.

Technical data

Torque [Nm] depending on working pressure

Inlet pressure [MPa]	Piston diameter [mm]															
	52	63	75	83	92	105	125	140	160	190	210	240	270	300	350	400
0,2	8,1	15	20,1	30,8	45	66	100	171	267	426	530	769	1174	1526	2285	3256
0,25	10,1	18	25	39	56	83	125	214	332	532	665	966	1462	1908	2856	4069
0,3	12,1	22	30	47	68	99	150	256	399	638	798	1154	1754	2289	3427	4883
0,4	16,1	29	40	63	90	132	200	342	532	852	1064	1539	2339	3052	4570	6511
0,45	18,1	33	45	70	102	149	225	385	598	958	1197	1731	2632	3434	5141	7325
0,5	20	36	50	78	113	165	250	427	665	1064	1330	1924	2924	3815	5712	8139
0,55	22	40	55	86	124	182	275	470	731	1170	1463	2116	3216	4197	6283	8953
0,6	24	44	60	94	135	198	300	513	798	1277	1596	2308	3509	4578	6854	9767
0,7	28	51	70	110	158	231	350	598	931	1490	1862	2693	4094	5341	7997	11394
0,8	32	58	80	125	181	264	400	684	1064	1702	2128	3078	4679	6104	9139	13022

Dimensions

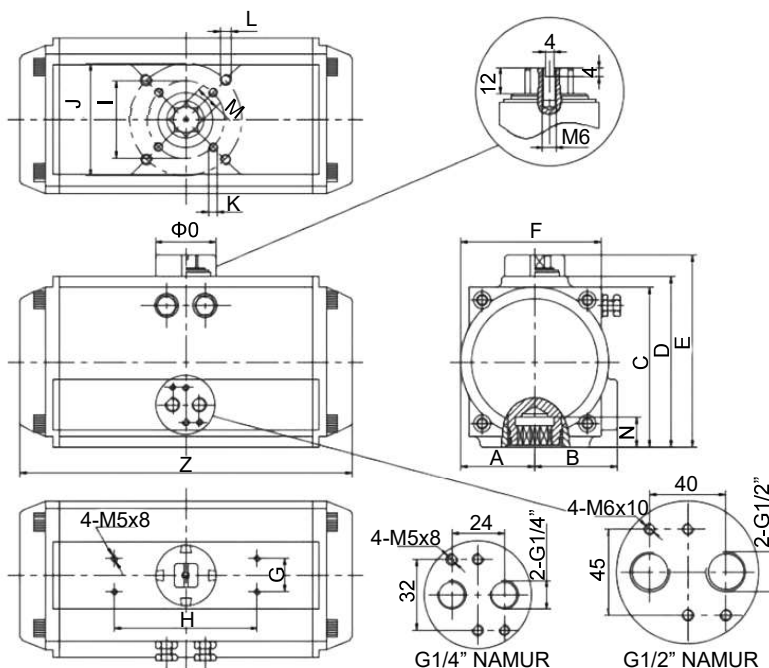

Ø	A	B	C	D	E	F	G	H	Ø I	Ø J	K	L	M	N	Z	O	Air source
52	30	41,5	65,5	72	92	65	30	80	36	50	M5x8	M6x10	11	14	147	40	NAMUR G1/4"
63	36	47	81	87,5	108	72	30	80	50	70	M6x10	M8x13	14	18	168	40	
75	42	53	94	99,5	120	81	30	80	50	70	M6x10	M8x13	14	18	184	40	
83	46	57	98,5	108,7	129	92	30	80	50	70	M6x10	M8x13	17	21	204	40	
92	50	58,5	111	116,5	137	98	30	80	50	70	M6x10	M8x13	17	21	262	40	
105	57,5	64	123	133	153	110	30	80	70	102	M8x13	M10x16	22	26	268	40	
125	67,5	74,5	146	155	185	128	30	130	70	102	M8x13	M10x16	22	26	301	55	
140	75	77	161	172	202	138	30	130	102	125	M10x16	M12x20	27	31	390	55	
160	87	87	184	197	227	158	30	130	102	125	M10x16	M12x20	27	31	458	55	
190	103	103	216	230	260	189	30	130	-	140	-	M16x25	36	50	525	80	
210	113	113	236	255	285	210	30	130	-	140	-	M16x25	36	50	532	80	
240	130	130	265	290	320	245	30	130	-	165	-	M20x25	46	60	602	80	
270	147	147	299	330	360	273	30	130	-	165	-	M20x25	46	60	722	80	
300	162	173	330	354	384	312	30	130	-	165	-	M20x25	46	60	820	80	
350	190	195	383	410	440	362	30	130	165	254	M20x25	8xM16x25	46	60	900	80	
400	260	260	441	466	496	450	30	130	165	254	M20x25	8xM16x25	46	60	940	80	