

# DOUBLE ACTING PNEUMATIC CYLINDERS

## DIN ISO 6431, VDMA 24562

### WITH END-POSITION LOCKING



**STRÁNSKÝ A PETRŽÍK**

Modern design, quality processing and high-quality of used parts - these are characteristics of the new cylinders series. Cylinders are equipped with automatic locking device in one or both end positions. When air supply failure occurs, cylinder is locked in its end position. Release then happens automatically after air supply is restored. Dimensions conform to the international standards ISO 6431, VDMA 24562 and NF E 49003.1, that is why it can replace a pneumatic cylinder, which is made by any producer to these standards. Fully adjustable cushioning at end of stroke and magnet for proximity switches are standard for this series. The proximity switches can be mounted directly to the tube's groove - so no brackets are necessary.



### Warning



For the correct function of unlocking the piston rod during start-up, it is necessary to use a throttle valve on the cylinder with a function of throttling the output.

Working pressure	0,6 MPa
Min. pressure	0,1 MPa
Max. pressure	1,0 MPa
Temp. range	-20°C to +80°C
Working medium	modified compressed air

Piston diameter [mm]	32	40	50	63	80
Thrust at 0,6 MPa [N]	482	754	1178	1870	3015
Thrust at 0,6 MPa [N] with double ended piston rod	415	633	990	1682	2720
Return force at 0,6 MPa [N]	415	633	990	1682	2720
Connection	G1/8"	G1/4"	G1/4"	G3/8"	G3/8"
Length of adjustable cushioning [mm]	17	17	17	16	20
Max. stroke [mm] *	1000*	1000*	1000*	1000*	1500*
Working speed [mm/s]	50 to 500				
Min. stroke for proximity sensing [mm]	17	21	25	25	25
Weight 0 mm stroke [kg]	0.50	0.78	1.38	1.81	3.84
Weight add. per 1 mm stroke [kg]	0.003	0.004	0.007	0.007	0.013
Weight 0 mm stroke [kg] with double ended piston rod	0.56	0.88	1.48	2.01	5.19
Weight add. per 1 mm stroke [kg] with dbl. ended piston rod	0.004	0.006	0.009	0.009	0.017

\*) Stroke of cylinder may be longer after agreement with our technical dept.

### Order codes

10213 60 00 050 0100

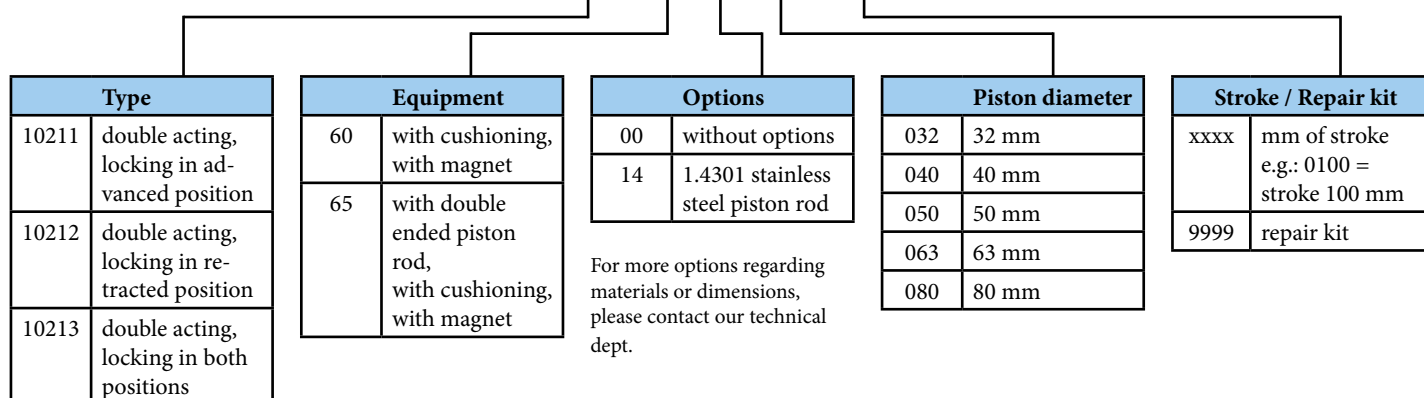

### Construction / materials

- caps: aluminium mold casting
- body: drawn dural profile, anodized
- piston rod: grounded round steel bar CK45 with hard chrome plated surface

**Dimensions**

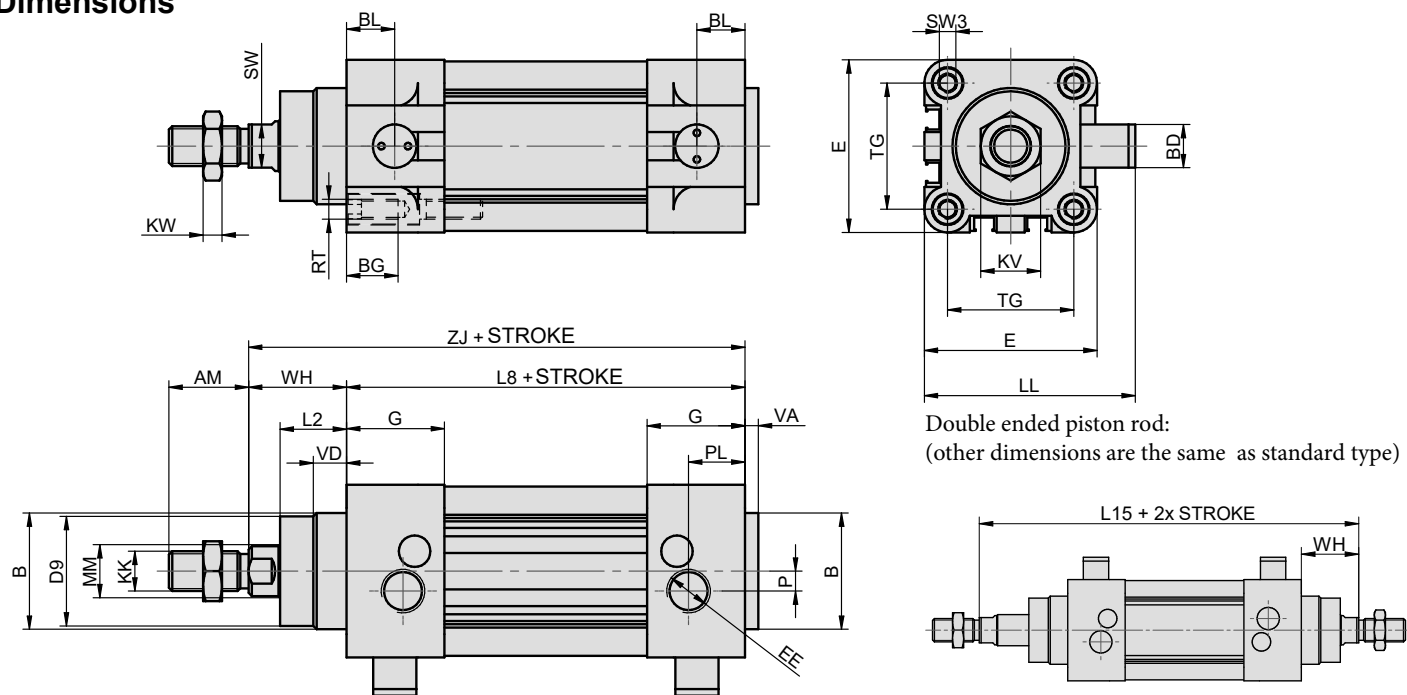

Double ended piston rod:  
(other dimensions are the same as standard type)

∅	AM	B	BD	BG	BL	D9	E	EE	G	KK	KV	KW	LL	L2	L8	L15	MM	P	PL	RT	SW	SW3	TG	VA	VD	WH	ZJ
32	22	30	13	16	11	28	45	G1/8"	25	M10x1.25	17	6	58.5	18	94	146	12	3	16	M6	10	6	32.5	4	10	26	120
40	24	35	13	16	14.5	33	54	G1/4"	30	M12x1.25	19	7	63.5	21.5	105	165	16	6	14	M6	13	6	38	4	11	30	135
50	32	40	16	14	15	39	65	G1/4"	30	M16x1.5	24	8	79	22	106	180	20	3	17	M8	16	8	46.5	4	5	37	143
63	32	45	16	17	15	44	75	G3/8"	30	M16x1.5	24	8	84	23	121	195	20	6	16	M8	16	14	56.5	4	5	37	158
80	40	45	36	20	15	44	95	G3/8"	30	M20x1.5	30	10	113.5	31	128	220	25	10	16	M10	21	17	72	4	5	46	174

**Mounting accessories**

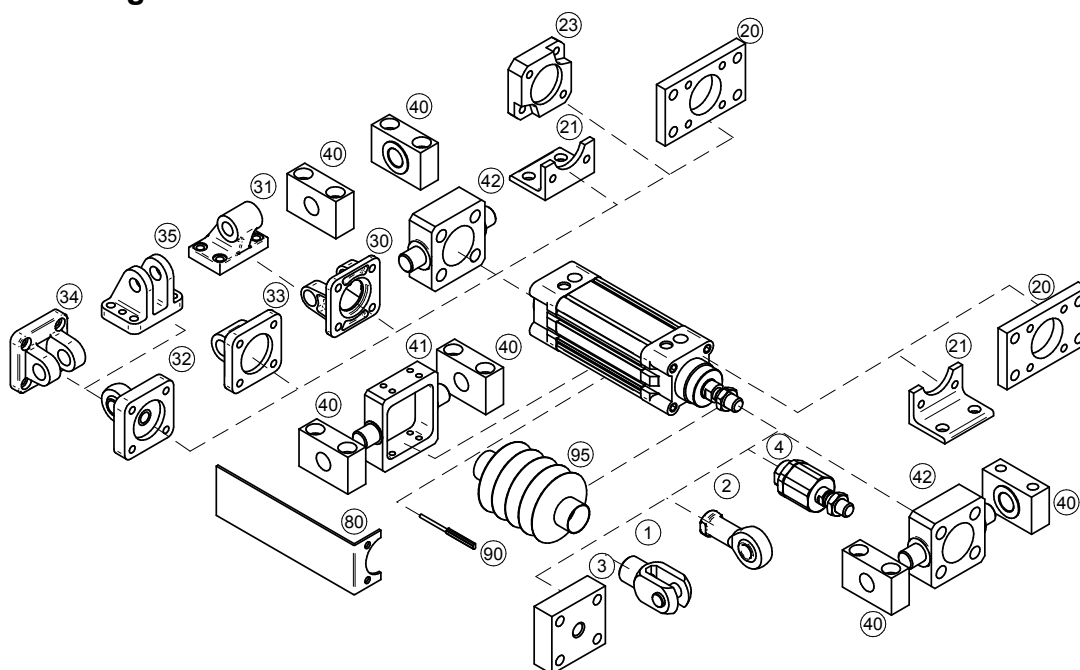

Mounting accessories	... see page
1 Piston rod clevis	... 4-2
2 Piston rod eye	... 4-3
3 Flanged piston rod coupling	... 4-2
4 Self-aligning piston rod coupling	... 4-3
20 Flange mounting	... 4-5
21 Foot mounting	... 4-5
23 Boxer flange mounting	... 4-6
30 Swivel flange	... 4-7
31 Clevis foot mounting	... 4-7
32 Swivel flange with spherical bearing	... 4-8
33 Swivel flange	... 4-8
34 Narrow swivel flange	... 4-9
35 Rectangular swivel flange	... 4-9
40 Trunnion mounting	... 4-10
41 Pivot pin	... 4-12
42 Pivot pin to front/end cap	... 4-13
80 Valve bracket	... 4-13
90 Proximity switch	... 3-2, 3-4
90 Proportional position sensor with analog output	... 3-6
95 Piston rod protective cover	... 4-4