



Pneumatic knocker could be used for bulk material release if the bulk material was adhered on walls of tubes or filling hopper. Compared to ball vibrator, knocker can be used for materials which solidify by intensive shedding; in this case individual shakes are well-proven. The principle is simple: by pressurize of air chamber the spring is pre-tensioned and by air exhausting the spring causes the impact. This system should be used, when there is no sufficient flow rate in the line for standard pneumatic knockers without springs.

Working pressure	0,6 MPa
Min. pressure	0,4 MPa
Max. pressure	1,0 MPa
Temp. range	-20°C to +80°C
Working medium	modified compressed air

Type	OKP32	OKP50	OKP80
Piston diameter [mm]	32	50	80
Stroke [mm]	25	35	50
Piston weight [kg]	0.16	0.75	2.60
Impulse [Ns]	1.5	7	20
Kinetic energy [Nm]	6.5	28	75

### Order codes

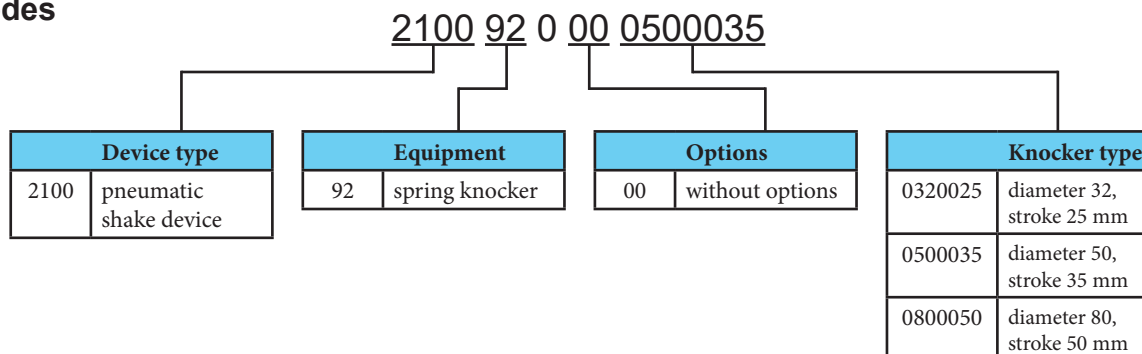

### Installation and operation notes

We recommend to fix fixing screws with Loctite 242E or similar adhesive.

There is necessary to check right tightening of fixing screws regularly to prevent their releasing.

The quick exhaust valve and connections of both chambers are included in delivery, compressed air should be connected to the quick exhaust valve.

### Construction / materials

- flange: zinc plated steel
- end cap: aluminium casting
- body: drawn dural tube, anodized
- piston: steel

**Dimensions**

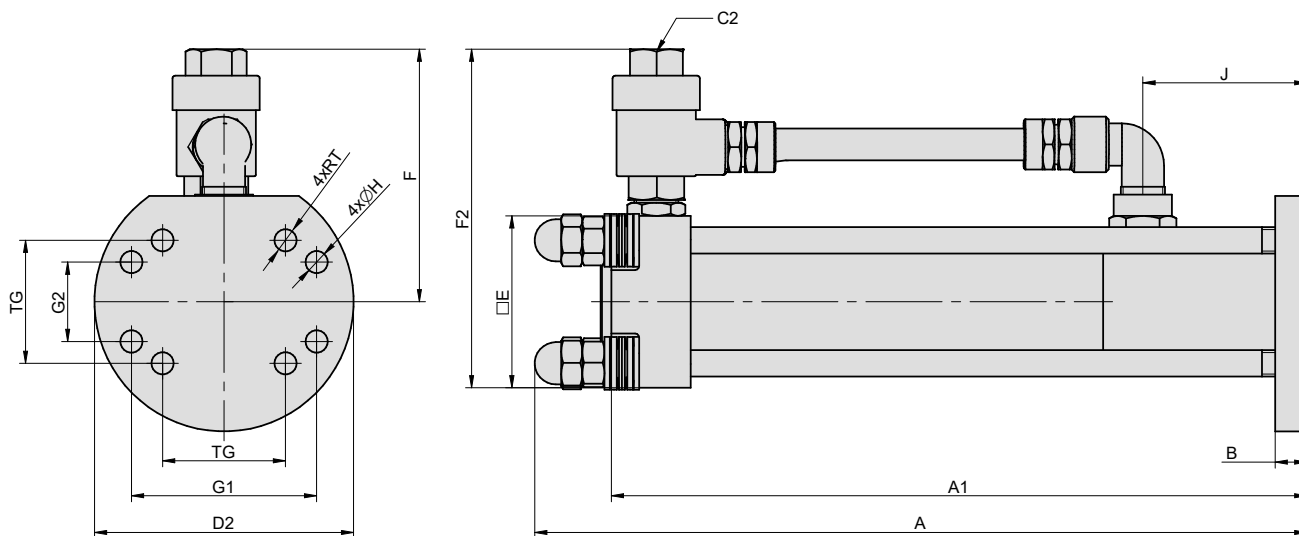

Ø	A	A1	B	C2	D2	E	F	F2	G1	G2	J	H	RT	TG
32	181	177	8	G1/4"	69	48	86	110	50	18	40	6.4	M6	32.5
50	292	263	12	G3/8"	98	65	96	128	70	30	62	8.4	M10	46.5
80	338	309	20	G1/2"	150	94	126	173	110	60	58	13	M10	72

**Recommended connection**

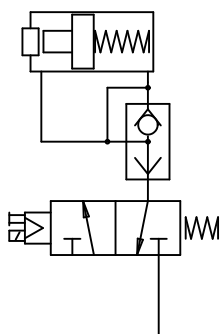

The 3/2 valve is suitable for knocker control. The force of knocker does not depend on distance between knocker and valve. We recommend to mount the valve outside, where the knocker's shocks couldn't reach the valve.



**Attention: knocker is designed for make shocks only by movement of piston towards to front cap with flange! Do not allow to make shocks during piston return movement in any case! It may be the cause of permanent damage of end cap of knocker!**

**Mounting examples**

Single knocker on filling hopper

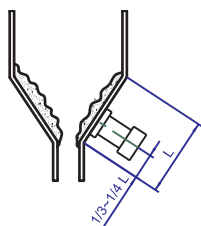

Two knockers on filling hopper  
(edge distances should be different)

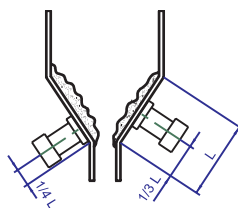

Single knocker on tube

