

# SINGLE ACTING PNEUMATIC CYLINDERS DIN ISO 6432



Cylinders are designed to meet the specifications of international standard ISO 6432. Cylinders aren't equipped with cushioning.



Working pressure	0,6 MPa
Min. pressure	0,15 MPa
Max. pressure	1,0 MPa
Temp. range	-20°C to +80°C
Working medium	modified compressed air

Piston diameter [mm]	12	16	20	25
Thrust at 0.6 MPa [N]*	66	121	188	295
Return force at 0.6 MPa [N]*	50	102	158	248
Spring restoring force [N]	11	11	13	13
Connection	M5	M5	G1/8"	G1/8"
Max. stroke [mm]	50	50	50	50
Weight 0 mm stroke [kg]	0.04	0.05	0.15	0.18
Weight add. per 1 mm stroke [kg]	0.0005	0.0005	0.0010	0.0013

\*) Cylinder will make out either thrust or return force, accordingly to the type (spring return / extend).

## Order codes

11005 10 00 020 0010

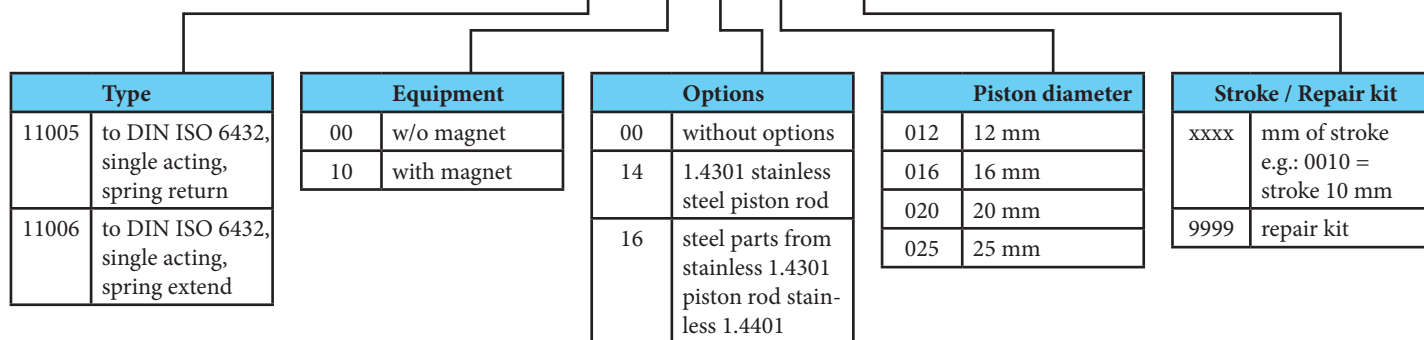

For more options regarding materials or dimensions, please contact our technical dept.

## Construction / materials

- caps: anodized dural
- body: drawn dural tube, anodized
- piston rod: grounded round steel bar CK45 with hard chrome plated surface

**Dimensions**

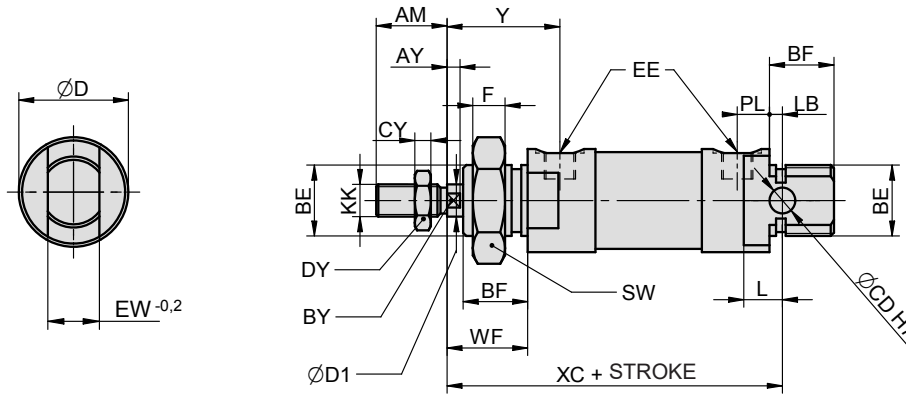

Ø	AM	AY	BE	BF	BY	CD	CY	D	D1	DY	EE	EW	F	KK	L	LB	PL	SW	WF	XC	Y
12	16	3	M16x1.5	15	5	6	3	22	6	10	M5	12	8	M6	10	4	5	24	20	75	25
12*	16	3	M16x1.5	15	5	6	3	22	6	10	M5	12	8	M6	10	4	5	24	20	80	25
12M	16	3	M16x1.5	15	5	6	3	22	6	10	M5	12	8	M6	10	4	5	24	20	80	25
12M*	16	3	M16x1.5	15	5	6	3	22	6	10	M5	12	8	M6	10	4	5	24	20	85	25
16	16	3	M16x1.5	15	5	6	3	25	6	10	M5	12	8	M6	11	5	5	24	20	82	25
16M	16	3	M16x1.5	15	5	6	3	25	6	10	M5	12	8	M6	11	5	5	24	20	87	25
20	20	4	M22x1.5	20	7	8	6	27.5	8	13	G1/8"	16	10	M8	12	3	9.5	34	24.5	95	34
25	22	4	M22x1.5	20	9	8	6	32	10	17	G1/8"	16	10	M10x1.25	12	4	10	34	25.5	104	35

Notice: M after piston diameter size means cylinder with magnetic piston.  
Notice \*) Values are valid for type 11006 with spring extended piston rod

**Mounting accessories**

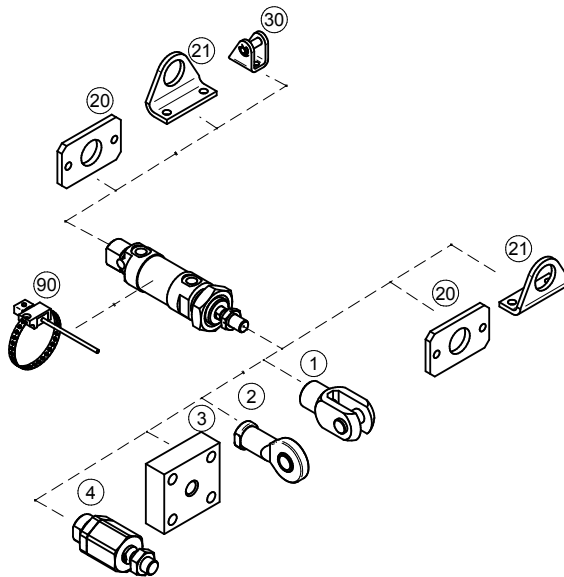

Mounting accessories	... see page
1 Piston rod clevis	... 4-2
2 Piston rod eye	... 4-3
3 Flanged piston rod coupling	... 4-2
4 Self-aligning piston rod coupling	... 4-3
20 Flange mounting	... 4-20
21 Foot mounting	... 4-20
30 Swivel flange	... 4-20
90 Prox. switch	... 3-2, 3-4