

FB-SERIES

VERTICAL MACHINING CENTER

Boxway

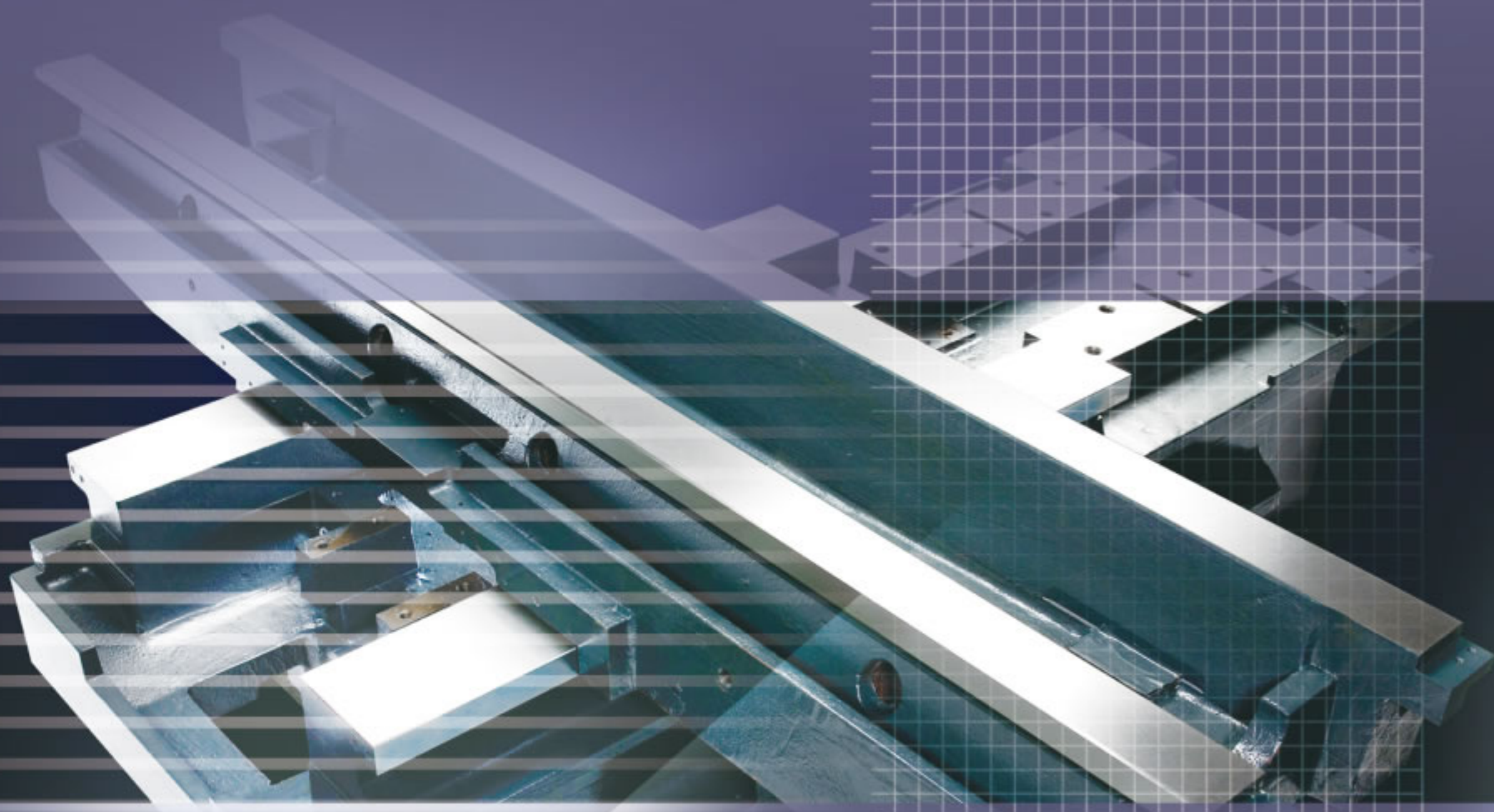

www.feeler.com



FAIR FRIEND GROUP

● FB Series

<http://www.feeler.com>

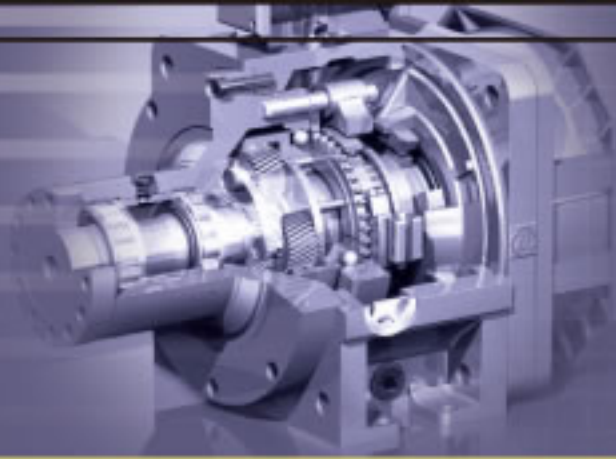

German ZF Gearbox (Optional)

- The 2-speed planetary gearbox provides spindle extremely smooth running and high torque output in high and low speed ranges.
- 4:1 gear ratio delivers extra high power and torque when spindle revolution is below 1,000rpm.

2 Box Guide Ways

FB-800(A) / FB-1000(A)

Design with Efficient Machining and Accuracy in Mind!

Massive Base And Saddle

The base and saddle are manufactured from Meehanite cast iron for outstanding material stability. This feature assures long-term deformation-free performance.

Box Ways on X, Y and Z Axes

Extra wide box ways on X, Y and Z axes are coated with low friction TURCITE-B wear-resistant media, providing increased cutting rigidity and long service life.

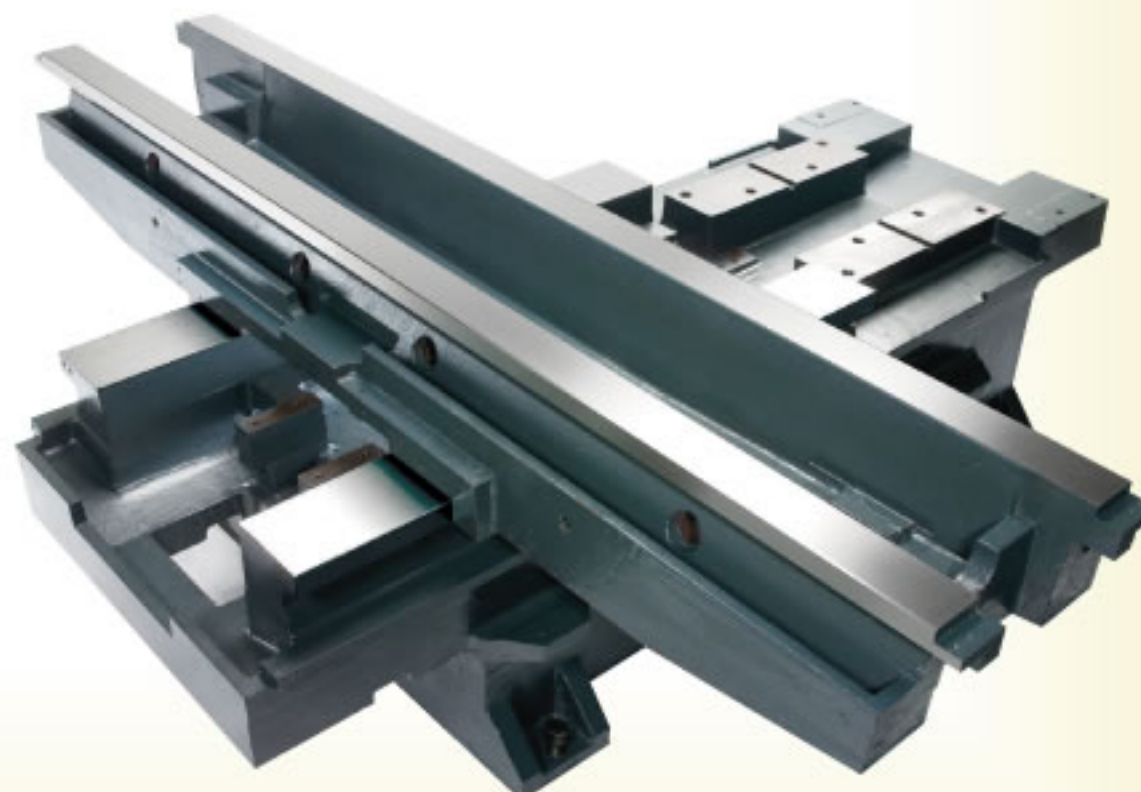

Specially Designed Spindle

- The spindle runs in P4 angular contact ball bearings which ensure the maximum rigidity and accuracy of spindle.
- The spindle vibration is less than 0.002mm at top speed.
- High torque, low noise spindle provides powerful cutting performance.
- Floating tool unclamping design combined with spindle axial clearance less than 0.002 mm provides stable tool clamping and unclamping.
- Advanced labyrinth spindle nose design along with air seal system prevents coolant and dust from entering the bearings. As a result, longer service life and better accuracy are achieved.

Machine Dimensions



22-tool Carrousel Type ATC

The 22-tool carrousel type tool changer meets your flexible machining requirements for molds and parts machining.

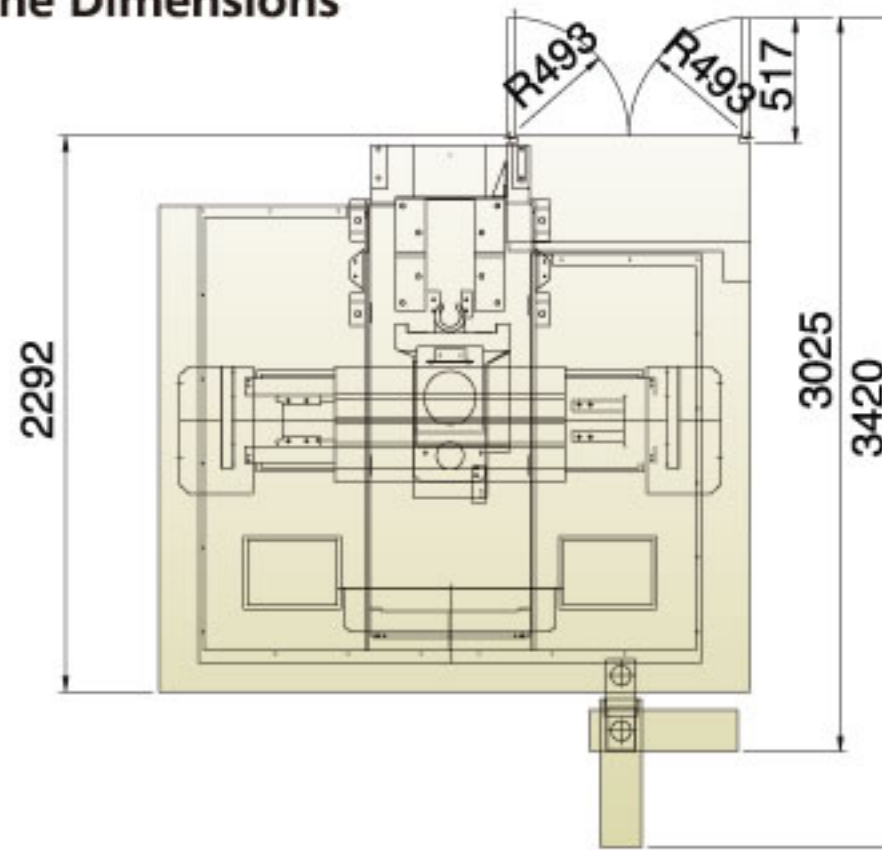

24-tool Arm Type ATC

The arm type tool changer features random tool selection for quick and smooth tool changing.

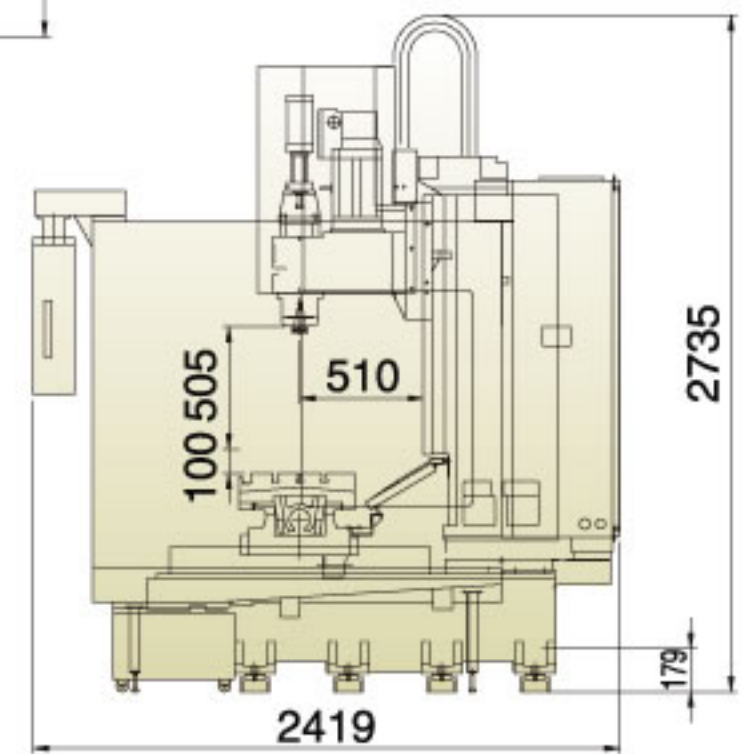
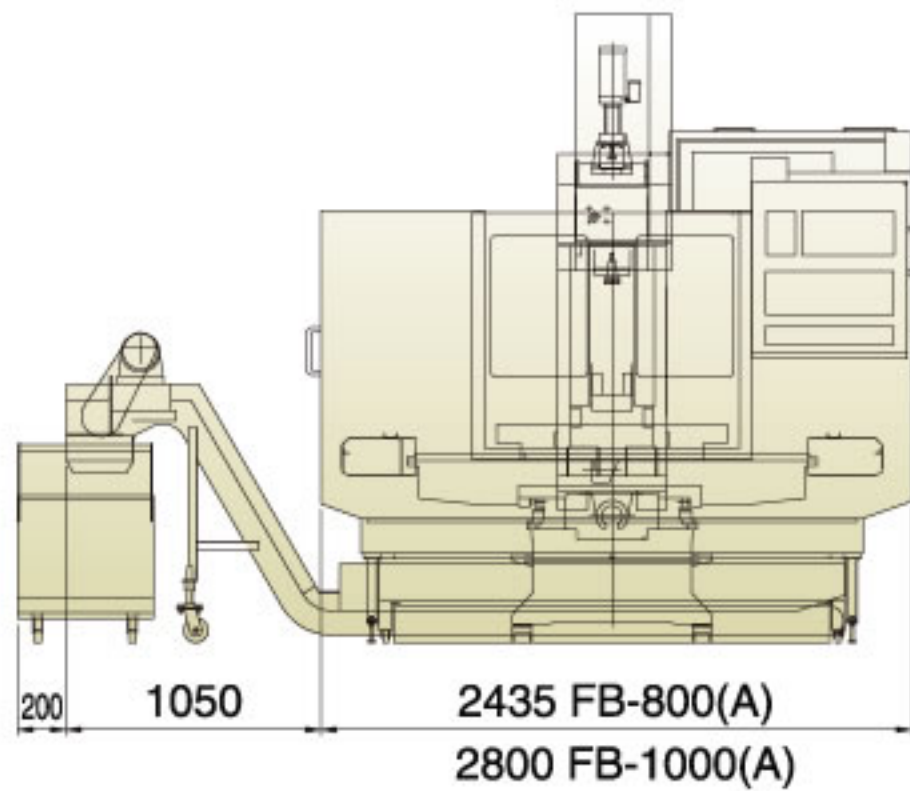

1 Million of Continuous Test

FEELER's ATCs are all subject to 1 million cycle of continuous test for durability and stability to assure maximum dependability of operational performance.

Working Capacity & Table Dimensions

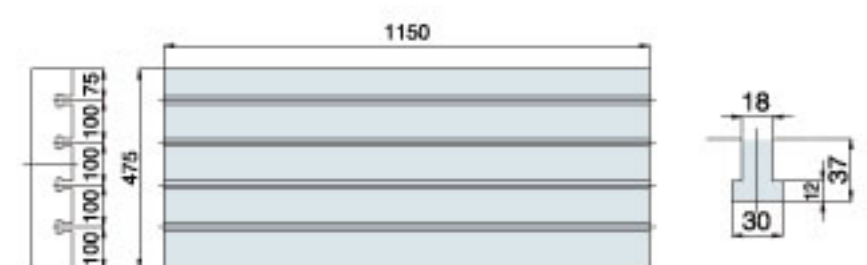
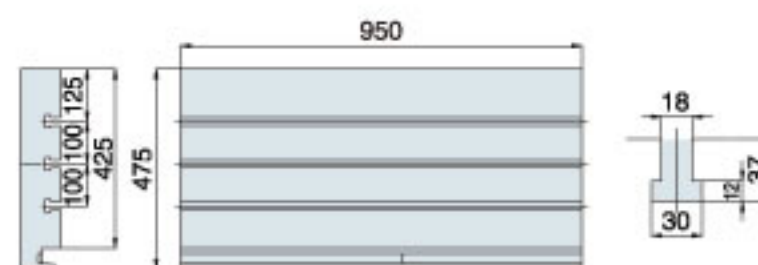
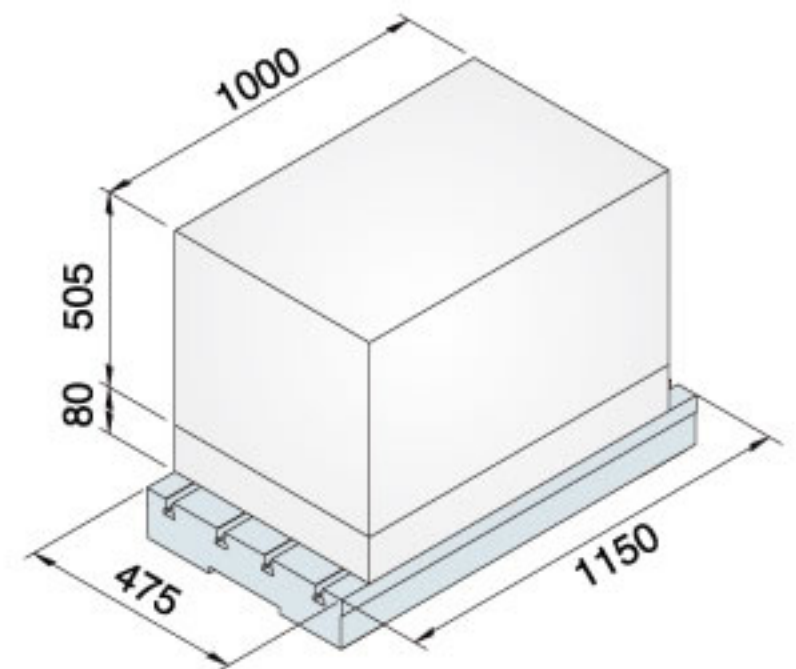
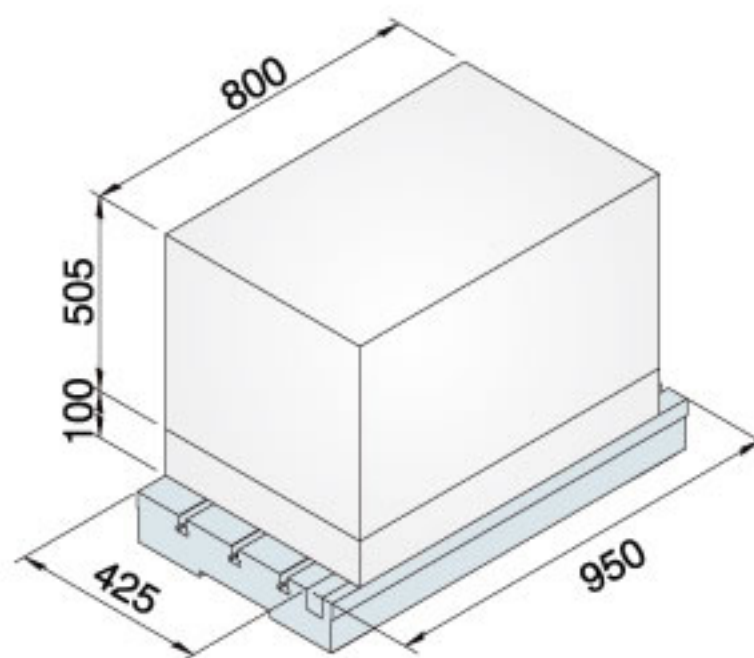

FB-800(A)

FB-1000(A)

Specifications:

MODEL	UNIT	FB-800(A)	FB-1000(A)
TRAVEL			
X-axis travel	mm	800	1,000
Y-axis travel	mm	500	500
Z-axis travel	mm	505	505
Spindle nose to table surface	mm	100-605	80-585
Spindle center to column surface	mm	510	510
Table surface to floor	mm	900	920
Table center to column surface	mm	255-755	255-755
TABLE			
Table dimension	mm	425 x 950	475 x 1,150
Max. loading weight	kg	500	500
T-slots (W x No. x P)	mm	18 x 3 x 100	18 x 4 x 100
SPINDLE			
Spindle speed	rpm	50-8,000	50-8,000
Spindle taper		7 / 24 taper No.40	7 / 24 taper No.40
Spindle motor	kW	7.5 / 11 kW (CONT / 30 min)	7.5 / 11 kW (CONT / 30 min)
FEEDRATE			
Rapid traverse X axis	m/min	24	24
Rapid traverse Y axis	m/min	24	24
Rapid traverse Z axis	m/min	15	15
AUTOMATIC TOOL CHANGER			
Tool changing time (tool to tool)	sec/Hz	7 sec / 60 Hz , 7.1 sec / 50 Hz (1.9 sec / 60 Hz , 2.2 sec / 50 Hz)	
ATC type		ARMLESS(SWING ARM)	ARMLESS(SWING ARM)
Tool selection		FIX ACCESS (RANDOM)	FIX ACCESS (RANDOM)
No. of tools		22 (24)	22 (24)
Pull stud		P-40T (45°)	P-40T (45°)
Max. tool weight	kg	7	7
Max. tool length	mm	250	250
Max. tool diameter	mm	Ø80	Ø80
Max. tool diameter (no adjacent tool)	mm	Ø150	Ø150
OTHER			
Floor space	mm	2,435 x 2,419	2,800 x 2,419
Machine weight	kg	5,000	5,100
Max. machine height	mm	2,735	2,735
Power capacity	KVA	20	20
Air source	bar	6	6

* Specifications are subject to change without prior notice.

Standard Accessories

- Leveling Bolts & Plates
- Rigid Tapping
- Spindle Air Blast
- Automatic Lubrication System
- 3-Axis Pre-tensioned Ballscrews
- Operation & Maintenance Service Manual
- Coolant Unit
- Fully Enclosed Splash Guard
- Clamping / Unclamping Device

Optional Accessories

- 12,000 rpm Belt Type Spindle
- 15,000 rpm D.D.S Spindle
- Chip Conveyor with Bucket
- 1.9 sec / 60 Hz Arm Type ATC
- Coolant Through Spindle
- Automatic Tool Length Measurement and Breakage Detection
- Spindle Oil Cooler
- Deep Hole Drilling
- Chip Screw
- 3-axis Linear Scales
- Programmable Nozzle
- Transformer

Power Diagrams

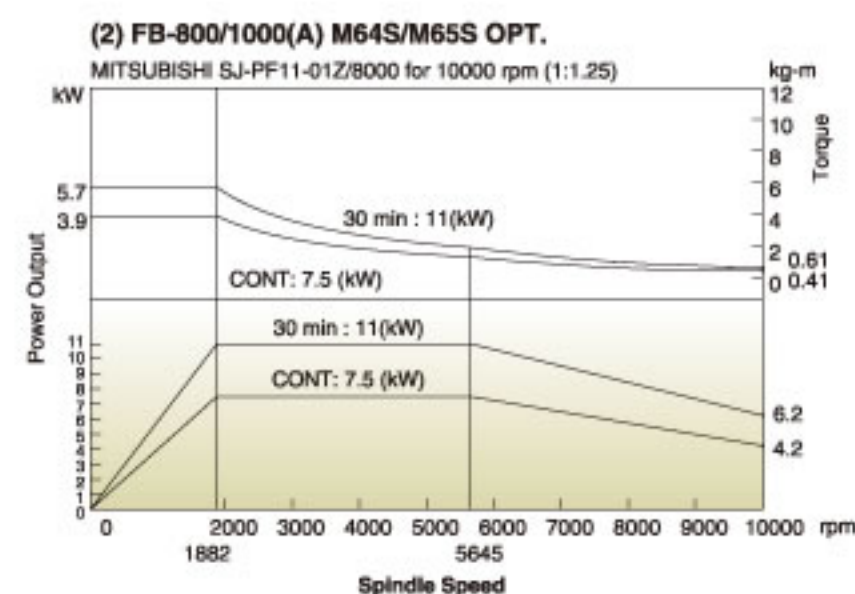
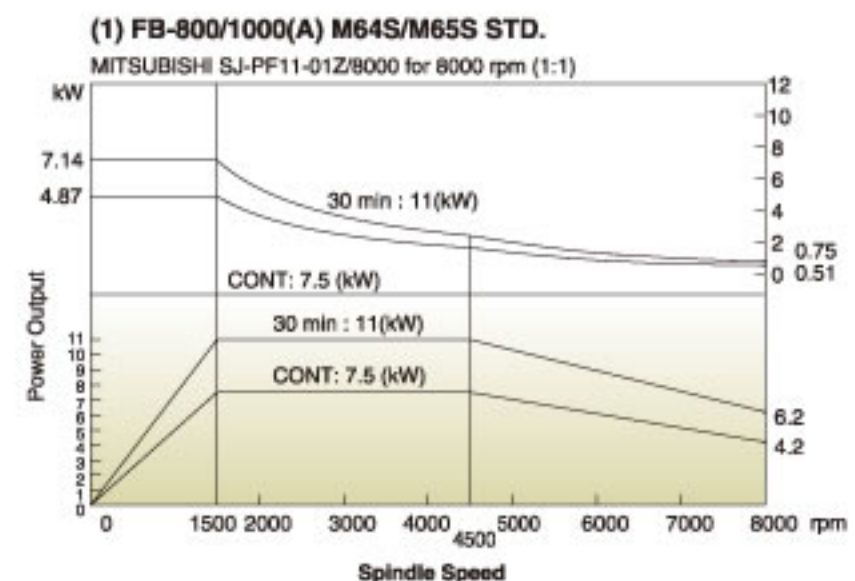
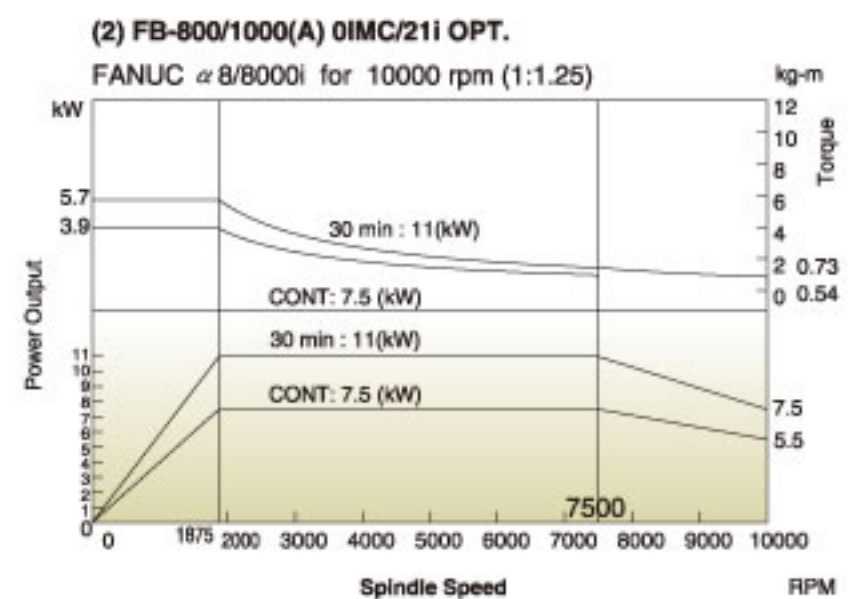
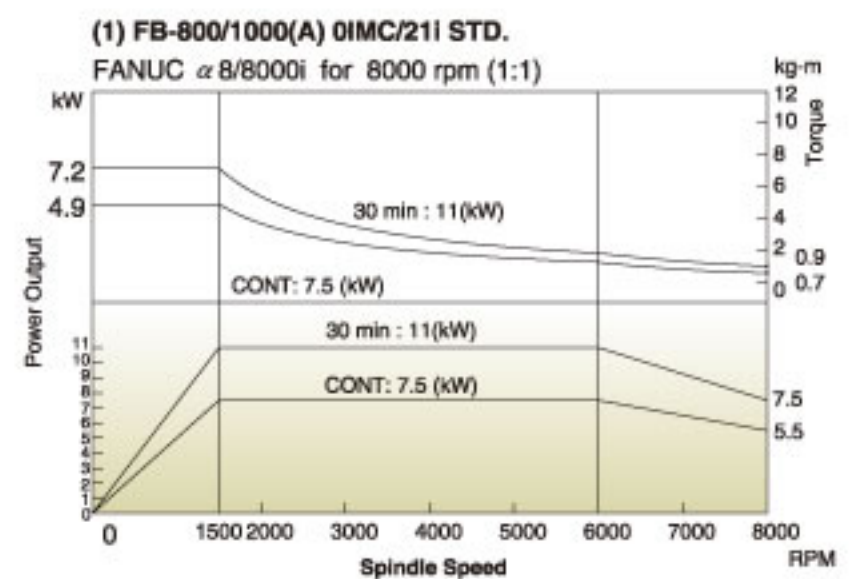

FAIR FRIEND GROUP

HEADQUARTER

No. 186, Yong Chi Road, Taipei, Taiwan.

Tel: +886-2-2763-9696 Fax: +886-2-2768-0636/37/39

<http://www.fairfriend.com.tw>

E-mail: chairom@fairfriend.com.tw

ISO 9001
ISO 14001



MACHINE TOOLS DIVISION

No. 133, Gong 1st. Road, Taichung Industrial Park, Taichung City, Taiwan.

Tel: +886-4-2359-4075 (MAIN), 2359-4845 (SALES DEP.)

Fax: +886-4-2359-0318 (MAIN), 2359-4873 (SALES DEP.)

<http://www.feeler.com>

E-mail: sales@feeler.com